

Fire sprinkler systems for domestic and residential occupancies – Code of practice

BS 9251:2020

BRITISH STANDARD

Publishing and copyright information

The BSI copyright notice displayed in this document indicates when the document was last issued.

© The British Standards Institution 2020
Published by BSI Standards Limited 2020

ISBN 978 0 580 [add ISBN here \(double-click to paste\)](#)

ICS [add ICS here \(double-click to paste\)](#); [add ICS here \(double-click to paste\)](#)

The following BSI references relate to the work on this document:

Committee reference [add committee here \(double-click to paste\)](#)

Draft for comment [add YY/XXXXXXXX DC here \(double-click to paste\)](#)

Publication history

[Add publication history here \(double-click to paste\)](#)

Amendments issued since publication

Date

Text affected

Foreword

Publishing information

This British Standard is published by BSI Standards Limited, under licence from The British Standards Institution, and came into effect on **XX Month 201X**. It was prepared by Subcommittee FSH/18/2, *Sprinkler systems*, under the authority of Technical Committee FSH/18, *Fixed fire fighting systems*. A list of organizations represented on this committee can be obtained on request to its secretary.

Supersession

This British Standard supersedes BS 9251:2005, which is withdrawn.

Relationship with other publications

Attention is drawn to the requirements of BS EN 806, with particular regard to backflow prevention, to BS EN 805 where appropriate, and to BS 1710 for guidance on identification and marking of pipework.

Sprinkler protection for industrial premises and commercial buildings other than those listed in this standard is specified in BS EN 12845. Where sprinklers are not installed primarily for life protection in domestic and residential occupancies, sprinkler installations conforming to BS EN 12845 might be more appropriate than those conforming to BS 9251.

Guidance on the application of sprinkler systems is given in BS 5306-0, BS 9999, the Building Regulations 2010, Approved Document B for use in England [1], [2], Wales [3], [4] and its equivalents in Scotland [5] and Northern Ireland [6].

The responsible BSi committee, FSH/18/2, had opposed the publication of BS EN 16925:2018: *Fixed firefighting systems. Automatic residential sprinkler systems. Design, installation and maintenance* in June 2019. This response was as a result of their collective opinion that BS EN 16925:2018 was inferior to BS 9251 which was based on 20 year's practical experience of using DD251 and BS 9251 and substantial testing at BRE Global and elsewhere.

The National Foreword to BS EN 16925 states:

“It is the view of the UK committee that some of the requirements in BS EN 16925– for example those relating to the necessary water application rates – are suboptimal to the recommendations in BS 9251:2014 and to the rates that have been in use in the UK to date. In particular, the application rates recommendations in BS 9251:2014 are based on independent testing of sprinkler heads undertaken on behalf of UK fire regulators. As such, they offer a significant degree of confidence in the reliability and efficacy of sprinkler systems designed to protect life in residential and domestic occupancies. The experience of real fires in premises protected by sprinklers designed and installed to BS 9251:2014 recommendations confirms that the minimum application rates recommended in BS 9251:2014 are appropriate. The committee also has concerns about a number of other aspects of BS EN 16925:2018, including system design and application, where the committee believes, based on experience, that existing UK practice is more robust than the requirements in BS EN 16925:2018.”

Approved Document B references the dated version of BS 9251:2014. Compliance with BS 9251:2014 confers a presumption of continued conformity with the relevant requirements of Approved Document B. Once this version of BS 9251 has been published, it can still be used in lieu of BS EN 16295 (e.g. for buildings less than 18m in height) to confer a presumption of continued conformity with the relevant requirements of Approved Document B.

This clarification is necessary because BSI is obliged to withdraw BS 9251:2014 but this does not mean it is technically unsuitable.

Information about this document

This is a full revision of the standard, and introduces the following principal changes:

- introduction of building categorization based on occupancy risk;
- change of building height limit;
- variation in sprinkler head design density;

- increase in sprinkler head spacing;
- expanded guidance on preliminary work and consultation;
- expanded guidance on water supplies;
- additional measures for vulnerable people and multi-occupancy premises.

This British Standard is intended for the use of designers, engineers, architects, surveyors, contractors, installers and authorities having jurisdiction.

Product certification/inspection/testing

Users of fixed firefighting systems are strongly advised to consider the desirability of third-party testing/inspection/certification of conformity to the relevant standards.

Test laboratories should be accredited by UKAS to BS EN ISO/IEC 17025, with a scope of accreditation which includes the applicable test protocols.

Certification bodies (products and services) should be accredited by UKAS to BS EN ISO/IEC 17065, with a scope of accreditation which includes the applicable product or system standards.

Certification bodies (persons) should be accredited by UKAS to BS EN ISO/IEC 17024, with a scope of accreditation which includes the applicable competency area.

Use of this document

As a code of practice, this British Standard takes the form of guidance and recommendations. It should not be quoted as if it were a specification and particular care should be taken to ensure that claims of compliance are not misleading.

Any user claiming compliance with this British Standard is expected to be able to justify any course of action that deviates from its recommendations.

It has been assumed in the preparation of this British Standard that the execution of its provisions will be entrusted to appropriately qualified and experienced people, for whose use it has been produced.

Presentational conventions

The provisions of this standard are presented in roman (i.e. upright) type. Its recommendations are expressed in sentences in which the principal auxiliary verb is “should”.

Commentary, explanation and general informative material is presented in smaller italic type, and does not constitute a normative element.

Contractual and legal considerations

This publication does not purport to include all the necessary provisions of a contract. Users are responsible for its correct application.

Compliance with a British Standard cannot confer immunity from legal obligations.

Particular attention is drawn to the Water Supply (Water Fittings) Regulations 1999 [7], the Water Supply (Water Fittings) (Scotland) Byelaws 2014 [8] and the Water Regulations (Northern Ireland) 2006 [9] in respect of requirements for any fire sprinkler system which conveys, or is likely to convey, water supplied by a water undertaker or licensed water supplier.

0 Introduction

Sprinkler systems have demonstrated their value in protecting life and property in industrial and commercial applications for many years. The advent of sprinklers that operate at an earlier stage in the development of a fire, plus the recognition that the largest numbers of deaths from fire occur in the home, have led to the introduction of sprinkler systems specifically designed for domestic and residential occupancies.

A correctly designed and installed sprinkler system can detect and control a fire at an early stage of development and activate an alarm. Operation of the system rapidly reduces the rate of production of heat and smoke, allowing more time for the occupants to escape to safety or be rescued.

This British Standard accordingly covers design, installation, components, water supplies, maintenance and testing of residential sprinkler systems installed for the purpose of reducing risk to life.

In classifying the design of the system for any occupancy, care needs to be taken when considering the fire loading such that it does not exceed that which would normally be expected in that occupancy.

Residential sprinkler systems consist of a water supply, backflow prevention device (e.g. check valve), stop valve, priority demand valve (where required), automatic alarm system and pipework to sprinkler heads. The sprinklers are fitted at specified locations, the appropriate sprinkler type being used for each location. The main elements of a typical residential sprinkler system are shown in Annex A.

Sprinklers operate at a predetermined temperature to discharge water over a known area below. The flow of water thus initiated causes the actuation of an alarm. Only those sprinklers operate which are individually heated above their operating temperature by the heat from the fire.

The provision of a sprinkler system does not negate the need for other fire precautions or practical measures, which can include structural fire resistance, escape routes, fire detectors and good fire safety management practices. Even with the installation of a sprinkler system, normal actions on the discovery of a fire need to be taken, such as immediate evacuation and the calling of the fire service. The sprinkler system is normally only to be turned off following liaison with the fire and rescue service and when it is deemed safe to do so.

Sprinkler system maintenance is not complex but is essential (see Clause 7). It is important that owners and occupiers are provided with adequate information.

Systems installed in accordance with this standard are primarily for the purpose of reducing risk to life, and are expected to prevent flashover (i.e. total involvement) in the room of origin of the fire and thus provide increased time for occupants to escape or be rescued.

1 Scope

This British Standard gives recommendations for the design, installation, components, water supplies and backflow protection, commissioning, maintenance and testing of fire sprinkler systems installed for life safety purposes with additional benefits for property protection.

This British Standard also gives recommendations for sprinkler protection of domestic and residential premises where the building height is either more than four storeys or 18 m and above, whichever is the lower.

The recommendations of this British Standard are also applicable to any addition, extension, repair or other modification to a residential sprinkler system.

2 Normative references

The following documents, in whole or in part, are normatively referenced in this document and are indispensable for its application. For dated references, only the edition cited applies. For undated references, the latest edition of the referenced document (including any amendments) applies.

BS 5839-1:2013, *Fire detection and fire alarm systems for buildings – Part 1: Code of practice for design, installation, commissioning and maintenance of systems in non-domestic premises*

BS 5839-6:2013, *Fire detection and fire alarm systems for buildings – Part 6: Code of practice for the design, installation, commissioning and maintenance of fire detection and fire alarm systems in domestic premises*

BS 8558, *Guide to the design, installation, testing and maintenance of services supplying water for domestic use within buildings and their curtilages – Complementary guidance to BS EN 806*

BS EN 805, *Water supply – Requirements for systems and components outside buildings*

BS EN 806 (all parts)¹⁾, *Specifications for installations inside buildings conveying water for human consumption*

BS EN 1057:2006+A1:2010, *Copper and copper alloys – Seamless, round copper tubes for water and gas in sanitary and heating applications*

BS EN 10226-1, *Pipe threads where pressure tight joints are made on the threads – Part 1: Taper external threads and parallel internal threads – Dimensions, tolerances and designation*

BS EN 10226-2, *Pipe threads where pressure tight joints are made on the threads – Part 2: Taper external threads and taper internal threads – Dimensions, tolerances and designation*

BS EN 10255, *Non-alloy steel tubes suitable for welding and threading – Technical delivery conditions*

BS EN 12259-1, *Fixed firefighting systems – Components for sprinkler and water spray systems – Part 1: Sprinklers*

BS EN 12845:2015+A1:2019, *Fixed firefighting systems – Automatic sprinkler systems – Design, installation and maintenance*

BS EN ISO 9453, *Soft solder alloys – Chemical compositions and forms*

ASTM F442, *Standard specification for chlorinated poly(vinyl chloride) (CPVC) plastic pipe (SDR-PR)*

3 Terms and definitions

For the purposes of this British Standard the following terms and definitions apply.

3.1 alarm device

device for detecting water flow in or through a sprinkler system which initiates an alarm signal

3.2 alarm receiving centre

continuously manned premises, remote from those in which a fire detection and fire alarm system is fitted, where the information concerning the state of the fire alarm system is displayed and/or recorded, allowing the fire and rescue service to be summoned

3.3 alarm test valve

valve through which water can be discharged to test the operation of an alarm device

¹⁾ This standard also gives an informative reference to BS EN 806-2:2005.

3.4 area of operation

maximum area over which it is assumed, for design purposes, that sprinklers operate in a fire

NOTE This is sometimes referred to as the “assumed maximum area of operation”.

[SOURCE: BS EN 12845:2004+A2, 3.9, modified – Note from BS 5306-0:2011 added]

3.5 authority having jurisdiction (AHJ)

organization, office, or individual responsible for enforcing the requirements of legislation or standards, or for approving equipment, materials, an installation, or a procedure

3.6 backflow

movement of the fluid from downstream to upstream within an installation

[SOURCE: BS EN 1717:2000, 3.5]

3.7 backflow prevention device

device intended to prevent contamination of wholesome water by backflow in a water supply system

[SOURCE: BS EN 1717:2000, 3.6, modified – additional words included]

3.8 building height

expressed in metres or storeys

NOTE The number of storeys and building height is to be determined in accordance with UK building regulations guidance as appropriate – Approved Document B (England and Wales) [x], the Building Standards Technical Handbook (Scotland) [x] and Technical Booklet E (Northern Ireland) [x].

3.9 client

an individual, group or an organisation that uses professional advice and/or services of other individuals, groups or organisations to procure the installation of a sprinkler system

NOTE In most circumstances this is the building owner

3.10 compartment

area completely enclosed by walls and a ceiling, where any openings in the walls and ceilings are not more than 2 500 mm in width, and have either:

- a) a lintel depth of not less than 200 mm; or
- b) a single opening of not more than 900 mm in width without a lintel, with no other openings

NOTE This is not the same as a compartment as defined by building regulations.

3.11 competent person

individual, suitably trained and qualified by knowledge, understanding and practical experience and qualification, who is provided with the necessary instructions, to enable the required task(s) to be carried out correctly

3.12 concealed sprinkler

sprinkler with a cover plate that disengages when heat is applied

3.13 crawl space

area not used for storage, under a floor or roof, giving access to building services

3.14 design density

minimum density of discharge, in millimetres per minute of water, for which a sprinkler system is designed, determined from the discharge of a specified sprinkler or group of sprinklers, in litres per minute, divided by the area covered, in square metres

[SOURCE: BS EN 12845:2004+A2, 3.19, modified – some words changed]

3.15 effective capacity

volume of stored water available to a pump, taking into account the air gap at the top and the unusable water at the base of the tank, which is affected by a vortex letting air into the pump suction

3.16 fusible link sprinkler

sprinkler which opens when an element provided for that purpose melts

[SOURCE: BS EN 12259-1:1999, 3.13]

3.17 glass bulb sprinkler

sprinkler which opens when a liquid-filled glass bulb bursts

[SOURCE: BS EN 12259-1:1999, 3.13]

3.18 hydraulically most favourable area

area of operation for which the water flow is at its maximum for a specified pressure, measured at the main control valve or pump set

3.19 hydraulically most unfavourable area

area of operation for which the system pressure, when measured at the main control valve or pump set, is required to be at its maximum to achieve the specified design density

3.20 mains water supply

permanent network of pipes that convey wholesome water from a public or private water supply system to a customer service connection or user draw-off point

3.21 maximum flow demand

stabilized flow rate discharged from those sprinklers located at the hydraulically most favourable area when balanced to a fire pump's flow/pressure performance curve

3.22 pendent sprinkler

sprinkler in which the nozzle directs the water downwards

[SOURCE: BS EN 12259-1:1999, 3.20]

3.23 priority demand valve

valve for isolating the supply to the domestic service in the event of sprinkler operation

3.24 pump

automatically operated device that supplies water to a sprinkler system from a water storage facility or from a mains supply when the pressure in the system drops below a pre-determined value

3.25 recessed sprinkler

sprinkler in which all or part of the thermally sensitive element is set into the ceiling or wall

[SOURCE: BS EN 12259-1:1999, 3.21, modified – location reworded]

3.26 residential

designed for people to live in

3.27 residential occupancy

part of a building only containing dwellings

NOTE This includes common areas, such as separate small storage rooms up to 9 m² used only by the residents, the entrance area, boiler rooms, communal residents lounges and similar amenities.

3.28 residential pattern sprinkler

sprinkler which gives an outward and downward water discharge, designed and approved for use in domestic and residential occupancy

3.29 service pipe

pipe supplying water from a water supply to any premises that are subject to water pressure from that water supply

3.30 shadow area

small area which is not wetted by the residential sprinkler due to an obstruction such as a wall or partition

3.31 sidewall pattern sprinkler

sprinkler which gives an outward half paraboloid pattern of water discharge

3.32 sprinkler system

entire means of providing sprinkler protection in the premises, typically comprising, but not limited to, sprinkler heads, pipework, alarm devices and a water supply

3.33 stop valve

manually operated valve for isolating the flow of water in the sprinkler system pipework, typically kept in the fully open position

3.34 stored water supply

water, apart from mains water, available for the sprinkler system

NOTE For example, water stored in a tank/cistern or vessel.

3.35 upright sprinkler

sprinkler in which the nozzle directs the water upwards

[SOURCE: BS EN 12259-1:1999, **3.26**]

3.36 vulnerable people

individuals who are at greater risk from fire due to inability to easily evacuate without assistance, or who have a higher than average likelihood of experiencing a fire, or a combination of the two

3.37 water undertaker

company licensed to provide a public water supply

3.38 wholesome water

water suitable for human consumption

NOTE Attention is drawn to the definitions given in the Water Supply (Water Fittings) Regulations 1999 [7] and equivalents in Scotland [8] and Northern Ireland [9],

4 Preliminary work and consultation

4.1 Initial considerations

Before undertaking the design of a residential sprinkler system for a specific property, the designer should evaluate, as a minimum, the following factors before starting work on the project, obtaining specialist advice where necessary:

- a) the type of occupancy of the property (see **4.3**);
- b) the water supply requirements and availability; and
- c) any additional system enhancements required (see **4.2.3**).

NOTE 1 In some buildings or parts of buildings, a higher level of protection might be required than that provided in BS 9251 (see also Note 2 to 4.5).

NOTE 2 In buildings where there is a mix of residential, non-residential and commercial use (e.g. where flats are above shops, car parks, bin stores, offices and retail units), it is generally appropriate to protect the residential parts using BS 9251, and the non-residential parts using BS EN 12845.

Areas of the building that are not residential occupancies but not greater than Ordinary Hazard, as defined in BS EN 12845, should be protected with quick response type sprinklers in accordance with BS EN 12259-1 (see 5.6).

4.2 Consultation

COMMENTARY ON 4.2

Some premises might have multiple authorities having jurisdiction who might be concerned with life safety, property protection, business continuity, heritage preservation, and environmental protection. Some authorities having jurisdiction might impose additional requirements beyond those of this British Standard.

4.2.1 General

The client (and/or their representatives) should consult with all stakeholders regarding the requirements (specification) of the sprinkler system for new and extensions to existing systems. The consultation should include any relevant authority having jurisdiction (AHJs) or others who might have a direct interest in the installation, examples may include but not limited to the:

a) water undertaker or licensed water supplier;

NOTE 1 See Guidelines for the supply of water to automatic fire sprinkler systems [10].

b) fire authority;

c) licensing authority;

d) building control body;

e) conservation regulators;

f) insurer(s) of the dwelling and its contents;

g) sprinkler system designer; and

h) client, and their representatives e.g. consultants, architect, fire engineer, surveyor, building owner, building management, and/or the responsible person for the building etc.

NOTE 2 It is the responsibility of the client to provide the sprinkler system designer and installer with a specification (see 4.2.2) for them to design and install including whether any enhancements (see 4.2.3) to the system are applicable.

NOTE 3 It is the responsibility of the sprinkler system designer to ensure that the specification and/or fire strategy element for the sprinkler system (see 4.2.2) is appropriate for the building and its occupancy.

NOTE 4 There are occasions when a suppression system is used as a means of demonstrating compliance with building regulations or to compensate for, or overcome, circumstances where a building is unable to achieve compliance with guidance issued in support of building regulations. For example:

a) *an older building where the existing construction cannot achieve the recommended fire resistance appropriate to the use of the premises;*

b) *a new build that cannot meet the recommendations for fire appliance access;*

c) *loft conversions where it is either not practical or not possible to secure adequate means of escape; and*

d) *any building where there is doubt about adequacy of fire protection and safety provisions, or concerns over design of building in relation to fire safety e.g. stay-put policy, single stair case, combustible materials of construction, etc.*

As previously stated, it would be impractical for this standard to cover all circumstances. It is therefore essential that consultation take place, and where deemed appropriate to the circumstances there might be a need to increase the category of system, the design density and/or the resilience of the system. It is not implied that in all cases that there is necessarily a need to upgrade the category or increase resilience. It would be beneficial to justify any proposals by means of a fire safety strategy in such cases to support the proposals for the specific case.

4.2.2 Sprinkler specification

A sprinkler system designer requires a specification to design the system; consultation with stakeholders (see 4.2) should take place to develop and produce the specification for the designer.

The specification for the design should include the following information:

- a) Occupancy type for sprinkler protected area;
- b) Any information regarding water supplies;
- c) How sprinkler system alarms interact with fire alarm system (see 5.18);
- d) Details of any enhancements to sprinkler system (see 4.2.3); and
- e) Copy of fire strategy when a fire strategy has been produced;

There may be occasions that a specification and/or fire strategy is not provided. In these situations, the system should be designed in full accordance with this standard.

4.2.3 System enhancements

The system may need to have enhanced features to address areas of risk in addition to those identified in the design considerations in Tables 1 and 2.

System enhancements are measures in addition to those requirements detailed in Tables 1 and 2. Examples of enhanced measures include, increasing:

- a) category of system; and/or
- b) design density; and/or
- c) resilience of system (see 4.2.5).

NOTE 1 Considerations for enhancing a sprinkler system are addressed in 4.2.4

NOTE 2 When areas of additional risk have been identified, the sprinkler specification or fire strategy should justify how these areas of additional risk have been addressed.

NOTE 3 System enhancements (see 4.2.3) should be recorded on the compliance certificate (see 6.2.5).

4.2.4 System enhancements considerations

4.2.4.1 General

The system may need to be enhanced to address areas of risk in addition to those identified in the design considerations in Tables 1 and 2.

Examples of areas of additional risk for enhancing the system include:

- a) higher fire safety risk (see 4.2.4.2);
- b) compensatory features (see 4.2.4.3); and
- c) occupancy profile¹ - vulnerable people (see 4.2.4.4).

4.2.4.2 Higher fire safety risk

Risk of fire occurs in all buildings but where there are additional risks to what may be the norm, additional measures to mitigate these should be included.

NOTE Examples of additional risk include those with:

- a) *fire loading greater than that which would normally be found in a domestic or residential living room, kitchen or bedroom, or if the fire hazard is greater than that of a conventional domestic or residential occupancy;*
- b) *hoarders with restrictions to means of escape and a higher fire loading;*
- c) *time for firefighting operations in the fire compartment to commence may exceed duration of water supply category of system, e.g. high rise or complex buildings;*
- d) *older buildings with hidden voids and/or where compartmentation might not meet current standards;*
- e) *heritage residential buildings, where preservation of the building should also be considered;*
- f) *atria;*

- g) adjacent unsprinklered areas;
- h) fire engineered design solutions;
- i) mixed use buildings (see 4.1, Note 2); and

4.2.4.3 Compensatory features

A sprinkler system should be used as a compensatory feature in certain circumstances, including:

- a) older buildings where existing construction cannot achieve the required fire resistance appropriate for its use
- b) new build that cannot meet access and facility requirements for the fire service;
- c) loft conversions where it is either impossible or impractical to secure adequate means of escape
- d) any building where there is doubt about adequacy of fire protection and safety provisions, or concerns over design of building in relation to fire safety e.g. stay-put policy, single staircase, combustible materials of construction, etc.

4.2.4.3 Occupancy profile - vulnerable people

4.2.4.3.1 General

NOTE Additional measures may be required with higher risk profile occupants.

Vulnerability should be taken as a combination of hazard and likelihood and, therefore, a matter of risk:

- a) Hazard: Ignition source for a fire and materials to aid combustion (the fire itself);
- b) Likelihood: Likely occurrence of a fire starting (hazard being realized); and
- c) Risk: Individual being unable to escape in sufficient time to avoid injury or death from fire.

Individuals who are vulnerable to fire should be taken as those with a higher than average likelihood of having a fire or with poor reaction or realization of the danger presented by fire, or a combination of both.

4.2.4.3.2 Vulnerable person risk factors

The factors below are not a definitive list but should be taken as primary indicators of higher risk:

- a) higher likelihood of fire:
 - 1) high fire risk activities or habits, such as careless disposal of smoking materials or leaving cooking unattended;
 - 2) history of fire-setting behaviour;
 - 3) history of previous fires or evidence of near misses, such as scorch marks on clothing or furniture; and
 - 4) threats of arson;
- b) inability or willingness to escape:
 - 1) impaired mobility affecting ability to escape;
 - 2) impaired, due to cognitive ability to react to fire or warning devices;
 - 3) impaired senses affecting ability to respond to alarm;
 - 4) poor situational awareness; and
 - 5) alcohol or drugs, increasing the likelihood of a fire and lowering reaction to alarm.

NOTE Evidence for the first group [a)] can be through observation. These are factors affecting the likelihood of a fire occurring. The remainder [b)] might require confirmation from a medical or social care agency and are linked with their ability to escape.

The most vulnerable persons are influenced by factor(s) from both groups and should therefore be considered at greater risk.

4.2.5 Resilience of system

Additional measures to improve the performance and reliability of the system to address areas of higher risk, should include but not be limited to any of the following:

- a) increasing duration;
- b) the resilience of the water supply, including:
 - 1) provision of a back-up power supply to pump(s);
 - 2) additional pumps;
- c) upgrading system to a higher category (see **Table 1**) or to BS EN 12845;
- d) arrangements to maintain system integrity during maintenance or repair;
- e) remote monitoring of critical system components; and
- f) installation of a fire and rescue service inlet to supplement the water supply.

NOTE Fire and rescue service inlets are typically downstream of the pump(s). Where this is not possible due to pressure, the inlet can be used to refill dedicated sprinkler water storage tanks.

4.3 Category of system

The designer should at an early stage determine which category of system is applicable, as this affects various design considerations.

The category of system should be determined by the type of building as shown in Table 1.

The AHJ(s) should be consulted to agree which type of building applies, whether any enhancements to the system are applicable (see **4.2.3**), or whether an alternative system (e.g. BS EN 12845) is more appropriate.

NOTE See also clause **5.12.4**.

Table 1 – Category of system

Category of system	Description of building/occupancy
1	Single family dwellings such as: <ul style="list-style-type: none"> • Individual dwelling house • Individual flat^{B)} • Individual maisonette • Transportable home Houses of multiple occupation (HMOs) ^{A)} Bed and breakfast accommodation ^{A)} Boarding houses ^{A)}
2	Blocks of flats (less than 45 m in height) ^{C)} Small residential care premises with ten residents or fewer Sheltered and extra care housing ^{C)}
3	Residential care premises with more than ten residents Student accommodation (less than 45 m in height) Dormitories (e.g. attached to educational establishments) Hostels
4	High rise 45 m or higher

^{A)} Buildings with more than two floors and five or more lettable bedrooms are to be treated as Category 2.

^{B)} Where the majority of flats are to be sprinkler protected, the building is treated as at least Category 2.

^{C)} Where the fire strategy requires the communal rooms and corridors to be sprinkler protected, then the building should be treated as Category 3.

NOTE Whilst an increase in the classification might be appropriate, each special feature and mitigation needs to be assessed, with the designer assuming responsibility for the assessment.

5 Design

5.1 General

A residential sprinkler system should be designed by a competent person in accordance with this British Standard and the component manufacturer's instructions.

NOTE 1 Where there is a difference between this British Standard and the manufacturer's instructions; the limits of this British Standard are to be applied (e.g. sprinkler head coverage areas not be exceeded) and the most onerous design or performance criteria applied (e.g. where higher density application rates are required by manufacturers they are to be used).

NOTE 2 In residential tower blocks and other multi-storey residential buildings, it is often appropriate to design the sprinkler system so that most maintenance functions (see Clause 7) can be carried out from the common parts.

Where a sprinkler system is divided into zones, e.g. for ease of maintenance or reinstatement after a fire, each zone should:

- a) not cover more than one floor;
- b) have a lockable full-bore stop valve; and
- c) have a quarter turn drain valve.

5.2 System type

A residential sprinkler system should be a wet pipe system, i.e. one that is permanently charged with water.

5.3 Design density and duration of supply

5.3.1 General

The minimum design density and duration of the supply should be determined in accordance with the category of system as given in Table 1 and the minimum design parameters for that category of system in accordance with Table 2.

Table 2 – Minimum design parameters

Category of system (see Table 1)	Minimum design discharge density	Number of design sprinklers (see 5.5)	Minimum duration of supply
	mm/min		min
1	2.10 ^{A)}	1 or 2	10
2	2.80 ^{B)}	1 or 2	30
3	2.80 ^{C)}	2 to 4 ^{D)}	30
4	2.80	4	60

^{A)} Where a higher fire safety risk applies to a sprinkler system specification (see 4.2.4.3), the minimum design discharge density is increased to either:

- a) 2.80 mm/min for a single head operation, or 2.04 mm/min through each sprinkler operating simultaneously up to a maximum of two sprinklers in a single area of operation; or
- b) 4 mm/min for single head operation, or 2.80 mm/min through each sprinkler operating simultaneously up to a maximum of two sprinklers in a single area of operation.

The increased level of discharge density needed [a) or b) above] is to be agreed with the AHJ prior to installation, based on consultation (see 4.2).

^{B)} Where a sprinkler system has an enhancement (see 4.2.3), the minimum design discharge density is to be increased to 4 mm/min for single head operation, or 2.8 mm/min through each sprinkler operating simultaneously up to a maximum of two sprinklers in a single area of operation.

^{C)} Where a sprinkler system has an enhancement (see 4.2.3), the minimum design discharge density is to be increased to 4 mm/min for single head operation, or 2.8 mm/min through each sprinkler operating simultaneously up to a maximum of four sprinklers in a single area of operation.

^{D)} Where communal areas/corridors are managed areas and considered to be sterile within a fire strategy report and with agreement by the AHJ, the number of design sprinklers can be limited to two in these areas only.

NOTE The design density might need to be increased if sprinklers are to be used:

- a) as an enhancement (see 4.2.3), or
- b) on sloped ceilings, or
- c) as part of sidewall design.

5.3.2 Minimum design parameters

The minimum design discharge densities, number of design sprinklers capable of operating simultaneously in a compartment, and duration of supply should be in accordance with Table 2. For category 1, 2 and 3, the number of design sprinklers should be determined by the maximum number of sprinklers in any compartment (see 5.7), up to the maximum given in Table 2. For category 4, the value given in Table 2 should be used.

5.4 Extent of sprinkler protection

Sprinkler protection should be provided in all parts of the premises. However, unless required by a fire strategy or risk assessment, the following may be excluded:

- a) toilets or bathrooms with a floor area less than 5 m², with linings in accordance with BS EN 13501-1:2018, Class A1, A2-s3, d2 and B-s3, d2, and which are not prepared for white goods, such as washing machines or dryers;
- b) cupboards and pantries with a floor area of less than 2 m² or where the least dimension does not exceed 1 m;
- c) attached buildings, such as garages and boiler houses without direct access from within the protected building;
- d) crawl spaces;
- e) ceiling voids;
- f) external balconies permanently open to the outside;
- g) enclosed staircases and enclosed vertical shafts (e.g. lifts or service shafts) containing allowable products are BS EN 13501-1:2018, Class B-s3 or better for construction products and B(fl) or better for flooring (including sub categories such as d0,d1,d2 for construction

products and s1 and s2 for flooring.) surface spread of flame and constructed as a fire resistant separation (see 5.3);

- h) uninhabited loft/roof voids; and
- i) shadow areas where the cumulative dry area does not exceed 1.4 m² per sprinkler in accordance with Figure 1.

NOTE A fire strategy or risk assessment might demonstrate that extensive spread of fire or smoke, particularly between rooms and compartments, is likely to take place and therefore that the fire risk in the area is such that sprinkler coverage is necessary.

Figure 1 – Shadow areas

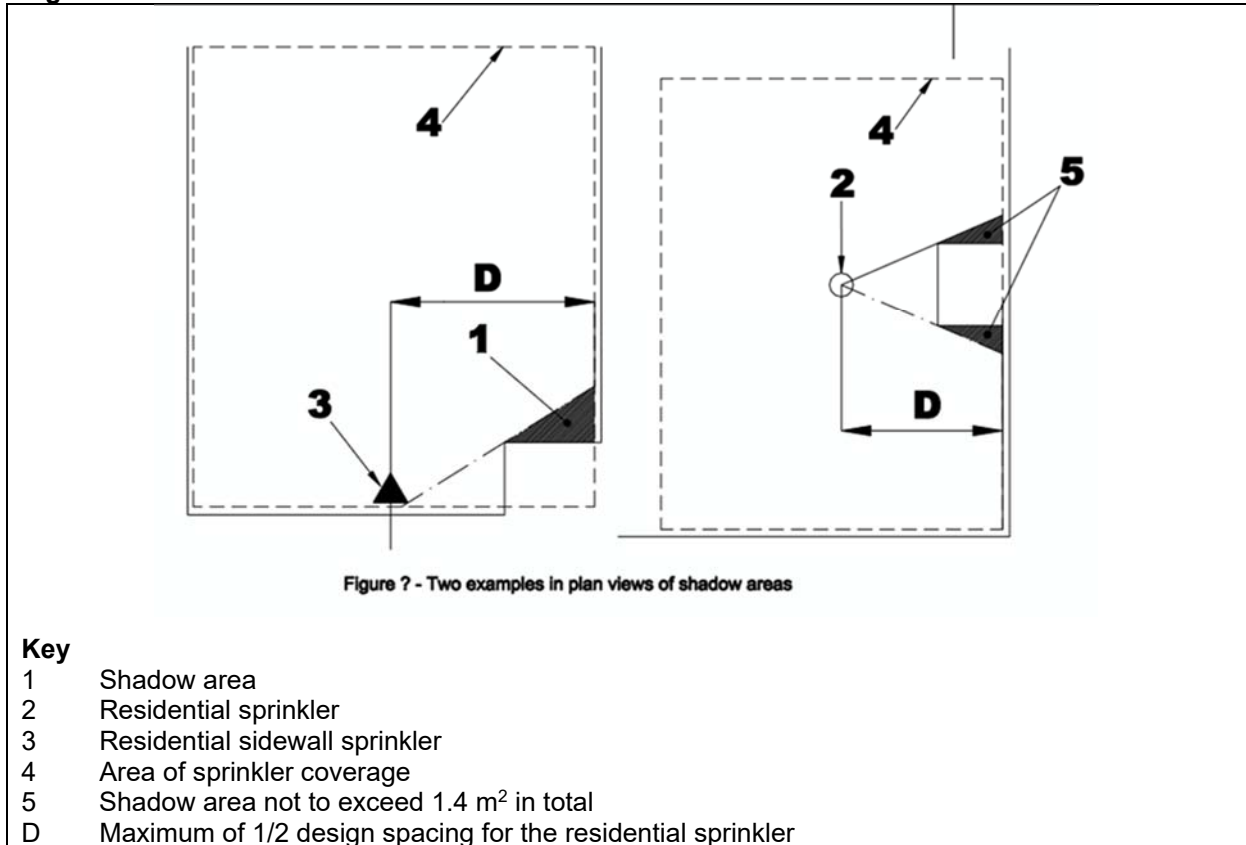

Small areas such as bay windows and similar features, provided the floor area does not exceed 1.6 m² (see Figure 2).

In addition, the additional floor area should not be greater than 0.6 m in depth at the deepest point of the architectural feature to the plane of the primary wall, where measured along the finished floor and the floor should not be greater than 2.7 m in length, where measured along the plane of the primary wall. A residential sprinkler should be located no more than half its design spacing from the wall (see Figure 2).

Figure 2 – Bay windows and similar features

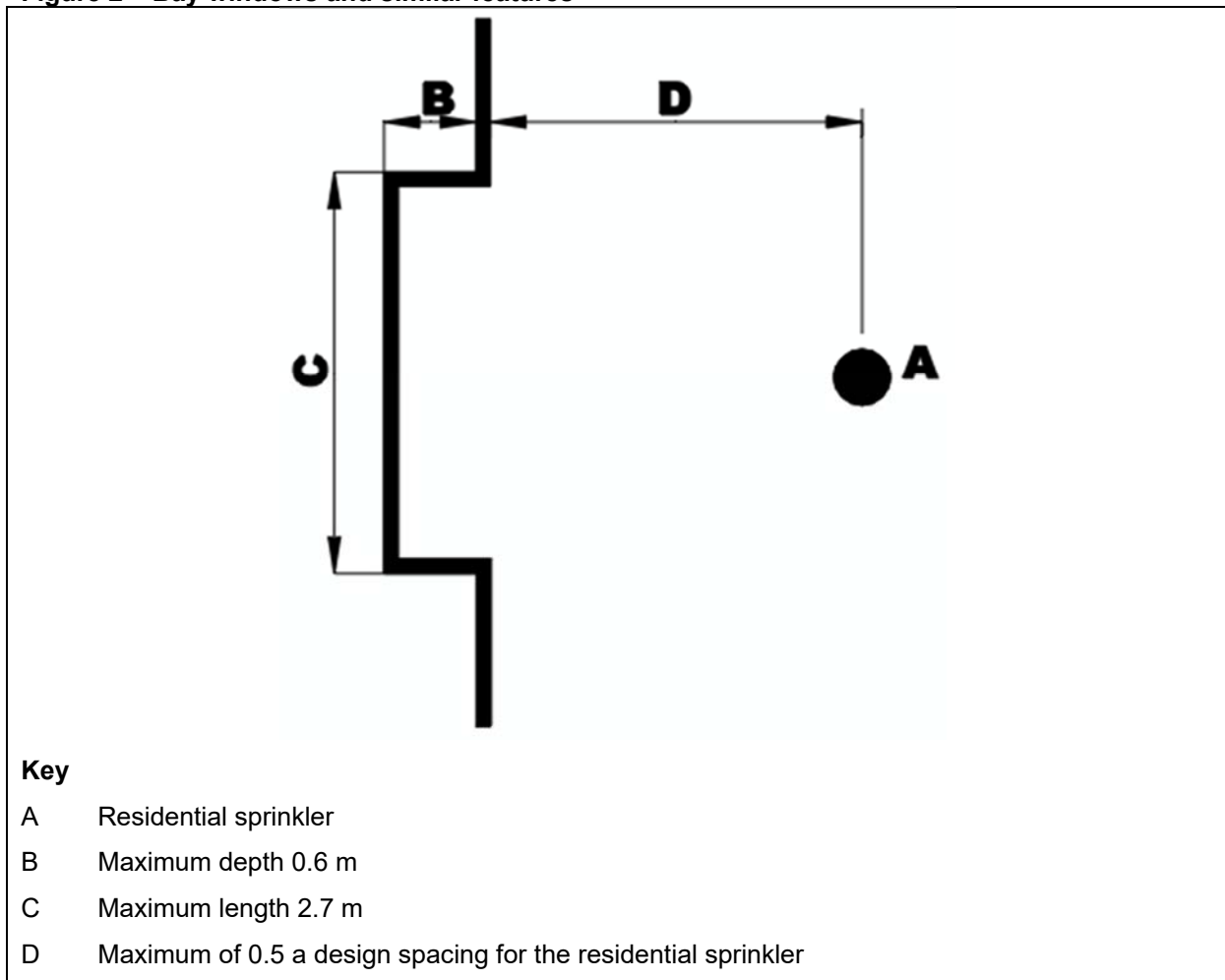

5.5 Areas that are not a residential occupancy

COMMENTARY ON 5.5

In some parts of the building, residential sprinklers might not provide adequate protection and the type of sprinkler selection, and classification of occupancies should be determined.

NOTE 1 Such areas could include commercial kitchens, plant and boiler rooms, bin stores, vehicle parking and garages.

NOTE 2 For a Category 1 system, a garage can be protected with residential sprinklers. Residential sprinklers have not been tested for fires in garages, but they do alert the occupants to the fact that there is a fire and reduce the risk of flashover and improve the chances of a safe evacuation.

5.6 Classification of non-residential occupancies and fire hazards

Limited areas of the building that are not residential occupancies but not greater than Ordinary Hazard, as defined in BS EN 12845, should be protected with quick response type sprinklers in accordance with BS EN 12259-1.

Provided that the individual compartment is less than 50 m²:

- a) a minimum design density of 5 mm/min should be applied;
- b) the area of operation should be taken as four sprinklers or the number of sprinklers in the area if less; and
- c) heads should be spaced and located in accordance with BS EN 12845, Ordinary Hazard.

Provided that the individual compartment is more than 50 m² but less than 100 m²:

- 1) a minimum design density of 5 mm/min should be applied;
- 2) the area of operation should be taken as the smaller of the area defined in BS EN 12845 for Ordinary Hazard or that area of the building if less; and

3) heads should be spaced and located in accordance with BS EN 12845, Ordinary Hazard. All other non-residential areas should be sprinklered in accordance with BS EN 12845.

NOTE Plastic pipe systems might not be suitable for these areas. Refer to the manufacturer's instructions.

5.7 Sprinkler coverage and positioning

Residential sprinkler spacing and positioning should be in accordance with the following.

- a) The maximum area protected by each sprinkler should be in accordance with its approved listing performance or 25 m², whichever is the lesser.
- b) Sprinklers should be not more than 5.5 m apart or more than half the design spacing from any wall or partition.
- c) The distance between sprinklers within a compartment should be not less than 2.4 m, except where there is an intervening constructional feature preventing adjacent sprinklers wetting each other.
- d) Pendent and upright sprinklers should have heat-sensitive elements, not more than 100 mm below the ceiling and under no circumstances exceeding the manufacturer's approval listing, whichever is the lesser.
- e) Sidewall pattern sprinklers should have the top of the deflector within 100 mm to 300 mm below the ceiling and under no circumstances exceeding the manufacturer's approval listing, whichever is the lesser.
- f) The whole of the floor area and the walls from the floor up to 0.7 m below the ceiling should be wetted when the sprinklers are operated.
- g) For sloping ceilings, sprinklers should be positioned in accordance with the manufacturer's instructions.
- h) Sprinklers should be positioned such that the sensitivity and discharge pattern are not adversely affected by obstructions, such as constructional beams, smoke alarms, light fittings or other sprinkler heads (refer to manufacturer's instructions for guidance).
- i) Sprinklers should be positioned a sufficient distance from any heat sources (e.g. fireplaces, stoves, ovens, kitchen ranges, hot air flues, hot water pipes, hot air diffusers, water heaters, heat generating light fixtures) in accordance with the sprinkler head manufacturer's instructions.
- j) The potential for a shielded fire to develop should be taken into account.
- k) Sprinklers should be not less than 100 mm or the manufacturer's recommended distance, whichever is greater, from any wall or partition.

5.8 Ceiling pockets

COMMENTARY ON 5.8

Ceiling pockets are architectural features that result in different parts of the ceiling being at different heights, where pockets are effectively formed. This is sometimes referred to as a coffered ceiling.

Sprinklers should be installed in each ceiling pocket unless the:

- a) total cumulative volume of all ceiling pockets in a compartment does not exceed 2.8 m³;
- b) depth of the unprotected ceiling pocket does not exceed 300 mm;
- c) surrounding floor area under any unprotected ceiling pocket is protected by sprinklers at the lower ceiling elevation; and
- d) ceiling pocket should be constructed of materials in accordance with BS EN 13501-1:2018, Class A1, A2-s3, d2 and B-s3, d2.

5.9 Residential pattern sprinkler heads

5.9.1 General

Except where stated, sprinkler heads used in the residential parts of the building should be in accordance with BS EN 12259-14 (or another standard as agreed with the AHJ).

Sprinkler heads should be of pendent, upright or sidewall spray pattern types suitable for flush, recessed or concealed installation.

Only new sprinkler heads should be used. Any sprinkler head removed from a system should be discarded.

NOTE In non-residential parts of the building or in residential parts with sloped ceilings where residential sprinkler heads are not appropriate, sprinkler heads conforming to BS EN 12259-1 can be used.

5.9.2 Minimum operating pressure and flow

The minimum nominal k -factor should be not less than 40 L/min/bar^{0.5}.

The minimum operating pressure at any sprinkler head should not be less than 0.5 bar.

NOTE 1 bar = 10⁵ N/m² = 100 kPa.

5.9.3 Temperature rating of sprinklers

Sprinkler heads should have a thermal sensitivity rating in accordance with prEN 12259-14. Fusible link sprinklers should be colour coded on the frame or sprinkler body; glass bulb sprinklers should be colour coded by the bulb liquid in accordance with prEN 12259-14 or BS EN 12259-1.

The temperature rating of the sprinklers should be:

- a) the closest to but at least 20 °C greater than the highest anticipated ambient temperature of the location; and
- b) within the range of 79 °C to 107 °C when installed under glazed roofs.

NOTE For normal climatic conditions, the sprinkler temperature ratings are in the range of 57 °C to 77 °C.

5.9.4 Sprinkler connection

Sprinkler heads should be suitable for use with fittings threaded in accordance with BS EN 10226-1 and BS EN 10226-2.

5.10 Hydraulic calculations

Full hydraulic calculations should be carried out for each system to determine the required pressure and flow, which in turn determines the required water supply.

The hydraulic calculations should be carried out in accordance with Annex C to determine the hydraulically most unfavourable area for the system, based on the maximum number of heads assumed to be operating, the pipe configuration, head selection and category of system.

If the system uses stored water, an additional set of calculations should be undertaken to find the most favourable demand area, to determine the effective capacity of the stored water supply.

All possible locations for the most unfavourable and favourable areas of operation should be assessed, to determine the maximum required system pressure and system flow.

The system flow rate should be not less than:

- a) flow determined by multiplying the discharge density (see Table 2) by the maximum area of operation; and
- b) flow at the minimum pressure specified by the manufacturer for that area of operation; and
- c) minimum flow rate as per hydraulic calculations see Annex C

5.11 Water supplies

5.11.1 General

The design should identify water supply requirements (pressure, flow and duration) for the sprinkler system.

NOTE Where water is drawn from a public mains supply, attention is drawn to the legal requirement for water undertaker approval to be sought.

A suitable water supply should be identified at an early stage to avoid unnecessary work. The water supply should be able to provide the system design requirements in accordance with Table 2.

5.11.2 Types of supply

Sprinkler systems should be connected to a reliable supply, for example:

- a) mains water supply:
 - 1) mains pressure only; or
 - 2) mains water supply boosted by a pump;
- b) stored water supply:
 - 1) pump supplied from a water tank;
 - 2) regulated pressurized vessel; or
 - 3) gravity-fed stored water system.

5.11.3 Mains water supply

5.11.3.1 General

When planning to use a mains water supply, the minimum mains dynamic pressure and flow should be ascertained at a time of peak demand at the earliest opportunity so that there is sufficient pressure and flow available to allow the system to perform as designed.

NOTE 1 Where there is concern with regard to a mains water supply, a data logger can be used to establish a record of the standing pressure.

If the mains dynamic pressure at the design flow rate is insufficient, a pump can be attached to the mains (with permission from the water undertaker or licensed water supplier) to boost pressure, however it should not be used to increase flow rates. Only pumps which are designed to increase pressure should be used (see 5.12.1).

NOTE 2 Although an in-line booster pump increases pressure, it has minimal effect on increasing flow.

When the lowest pressure and flow characteristics from the mains water supply do not meet the sprinkler system design requirements, an alternative supply should be provided, e.g. a stored water supply (see 5.11.4).

5.11.3.2 Design flow rate for mains water supply connections

Where the mains water supply connection serves only the sprinkler system, the system should be capable of providing flow rates at the sprinkler heads in accordance with 5.3.3.

Where the mains water supply connection serves both the sprinkler system and the domestic or residential occupancy supply, the sprinkler system should be capable of providing flow rates at the sprinkler heads by:

- a) the operation of an automatic priority demand valve; or
- b) locating the domestic occupancy branch connection immediately adjacent to and in close proximity to the incoming water supply; or
- c) for category 1 systems (see 4.3), the flow rate in accordance with 5.3.3 plus at least 25 L/min;

- d) for category 2, 3 and 4 systems (see 4.3), the flow rate in accordance with 5.3.3 plus the design demand for the residency plus at least 50 L/min.

Where the connection to the mains water supply serves more than one dwelling, the system should be capable of providing the flow rates at the sprinkler heads in accordance with 5.3.3 at times of simultaneous peak domestic demand from all of the dwellings concerned.

5.11.3.3 Supply pipe sizing

The diameter of the water supply pipe to the sprinkler system should be large enough to accommodate the system flow requirements in accordance with 5.3.3.

The diameter of the service pipe for the sprinkler system fed by mains water supplies should be agreed with the water undertaker or licensed water supplier.

Losses in the service pipe between the connection point to the water supplier's main and the system design point should be taken into account when designing a town mains fed installation.

5.11.4 Stored water supply

5.11.4.1 General

Where stored water supplies are used, the most appropriate location for the storage volume should be identified.

An alarm to indicate low water levels should be provided for a stored water supply. The alarm should be situated in such a place or of sufficient decibels so that the alarm can be noticed and acted upon.

Storage tanks should be sited such that they can be inspected and maintained.

5.11.4.2 Stored water capacity

To establish the correct effective water storage capacity, the hydraulically most favourable area calculation should be balanced with the pump's performance curve to find the system's maximum flow demand. The maximum flow demand should then be multiplied by the system duration for the classification of risk to establish the minimum effective tank capacity.

The maximum flow demand calculation should be carried out in accordance with Annex C.

NOTE 1 The flow requirements at the most hydraulically favourable location are dictated by the performance of the pump selected for the system.

The volume of a stored water supply should be large enough to ensure that the effective capacity of the stored supply [see Figure 1a)] is sufficient for the duration for the category of system as determined in Table 2, or any increased capacity required for an agreed enhanced duration. The air gap at the top and unusable water at the base [see Figure 1b) and Table 3], which is affected by a vortex letting air into the pump suction, should be taken into account.

NOTE 2 An anti-vortex device can be installed to increase the amount of usable water at the base of the tank.

The storage tank should have a cover.

Figure 3 – Stored water supply

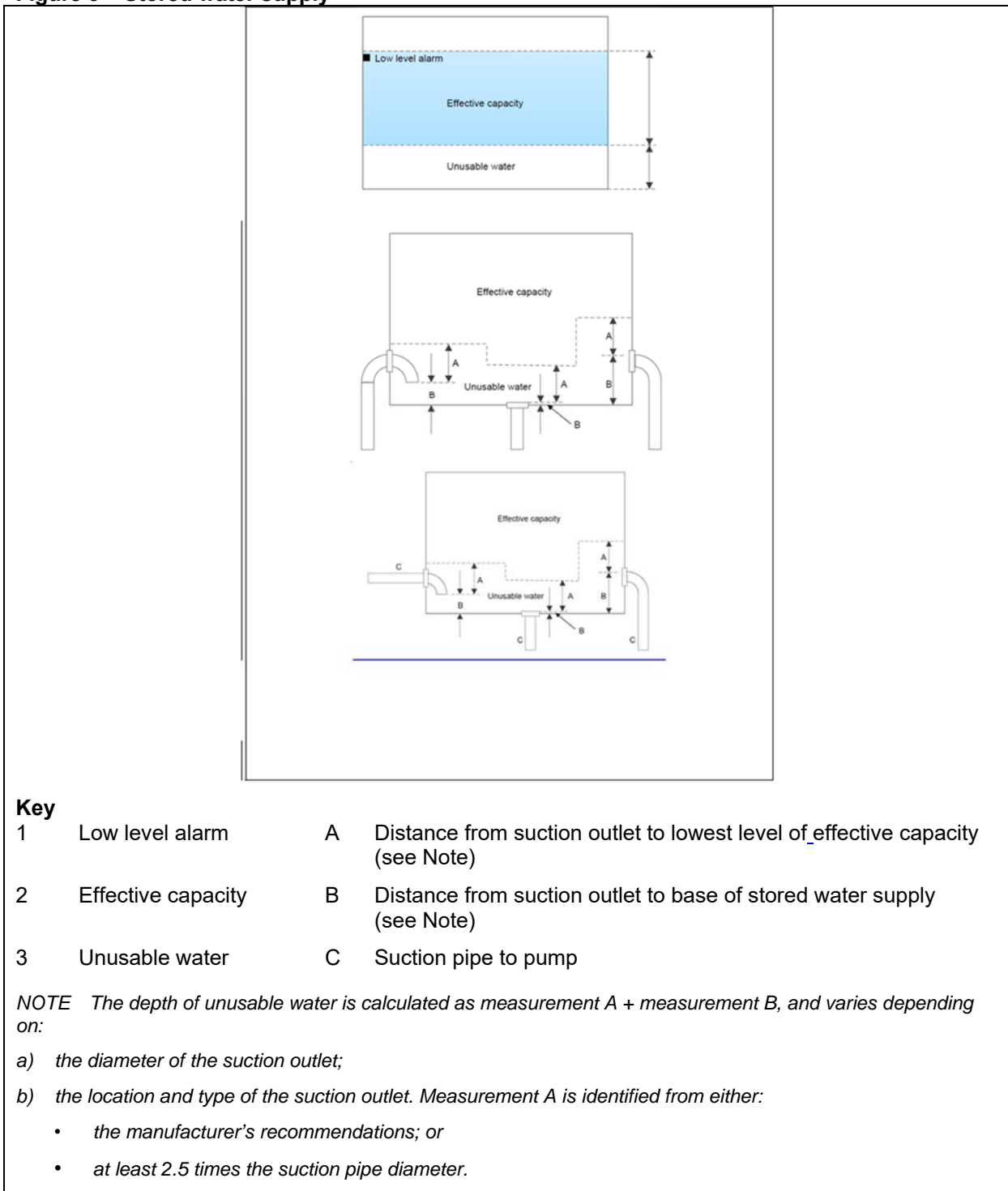

5.11.4.3 Dedicated stored water supply

Where the stored water supply is used exclusively for a sprinkler system, the effective capacity should be at least that determined by the sprinkler system design requirements.

5.11.4.4 Shared stored water supply

Where the stored water supply is used to supply both the sprinkler system and the domestic system (hot and cold water), the stored volume should be capable of providing:

- the building's peak domestic demand expected over the required duration of the sprinkler system run time, and the sprinkler system's maximum flow demand for the required duration of the sprinkler system run time; or
- for a system with a priority demand valve on each domestic branch/feed and a dedicated riser to the sprinkler system, the sprinkler system's maximum flow demand for the required

duration of the sprinkler system's run time. Priority demand valves should close, as necessary, in accordance with the design when there is a sprinkler activation.

In both cases, a low-level alarm system should be installed in each tank to raise the appropriate warning should the volume in the tank drop to a specific level.

The alarm should be set to trigger when the volume in the tank(s) is less than the combined volume, as defined in this subclause.

In the case of b), activation of the low-level alarm should also close off all domestic water demand via the priority demand valve(s).

NOTE 1 Where shared storage is to be considered, the stored water supply needs to be designed to avoid stagnation and ensure sufficient turnover (water usage) to maintain water quality.

NOTE 2 Where any proposed combined volume of stored water exceeds that required for domestic purposes, as set out in BS EN 806-2:2005, 19.1.4, it is likely that separate storage arrangements will be required by the water undertaker or licensed water supplier.

Where the sprinkler water is derived from the building's stored water supply and the domestic pump set, the following recommendations should be met.

A critical sprinkler low water alarm should be set at the point where any further reduction in the water level would affect the required effective capacity and the minimum duration of supply could not be guaranteed. On activation a priority demand valve should operate switching off the domestic supply and remain closed until manually reset.

NOTE 3 See Figure 3 for a typical arrangement.

NOTE 4 The peak flow demand of the building is not the same as the peak demand over a period of 10 min or 30 min.

NOTE 5 The peak flow demand of the building is the demand over a period of time equal to the sprinkler system's duration, and not the specific peak demand over a short period is not the same as the peak demand over a period of 10 min or 30 min.

NOTE 6 Where a low level switch is used, it must be suitable for use with wholesome water and installed in such a way that it complies with all necessary regulations.

5.11.4.5 Reduced capacity of stored water supply

A flow test facility should be permanently fitted to the tank infill arrangement so that the infill rate can be verified.

NOTE It is important that where tanks with a reduced capacity are dependent on the infill, the infill rate can be verified when the system is commissioned and at each maintenance interval.

The stored volume can be reduced if there is a proven rate of automatic infill from the water main, however, for category 2, 3 and 4 systems, two mechanical float valves should be used to provide infill, each being capable of supplying the infill rate independently. Only 80% of the proven infill should be used for reduction, with the proven infill rate measured at peak demand.

The reduced capacity should be not less than 60% of the effective capacity without infill.

5.11.5 Backflow prevention

The arrangement or device used to prevent backflow should be appropriate to the highest applicable fluid category to which the fitting is to be subjected on the downstream side.

NOTE 1 BS EN 1717 defines fluid categories and suitable arrangements and devices to protect against backflow. The requirements vary according to whether there is a direct connection or a tank supply, and whether additives are used.

NOTE 2 Attention is drawn to the Water Supply (Water Fittings) Regulations 1999 [7] and equivalents in Scotland [8] and Northern Ireland [9], in respect of the requirement for backflow prevention and for materials that are in contact with wholesome water (e.g. upstream of the backflow prevention device).

NOTE 3 Further information and guidance on the appropriate level of backflow prevention can be found in the WRAS Water Regulations guide [12] or obtained from the water supplier.

5.12 Pumps

5.12.1 General

COMMENTARY ON 5.12.1

The volume of the stored water supply is dictated by the flow performance of the pump selected at the most hydraulically favourable location.

The pumps can be dedicated or can supply both the sprinkler water and domestic water.

Only pumps suitable for use in sprinkler systems should be used. They should be installed and used in accordance with the manufacturer's instructions.

The pump should be able to supply the sprinkler system design pressure and flow requirements at the hydraulically most unfavourable and favourable location in accordance with **5.10** and Annex C. The suction pipe diameter should be not less than the pump's inlet diameter, and the velocity in the pump suction should be less than 1.8 m/s.

Where a pump is used to boost pressure, it should be selected so that it conforms to the sprinkler system design requirements. These pumps should be used on mains water-fed systems only for the purpose of boosting pressure.

Where a pump is used, it should be:

- a) located such that it is unlikely to be affected by a fire or protected in the event of fire;
- b) located where the temperature can be maintained above freezing, or trace heating or lagging applied;
- c) protected electrically by suitable fusing;

NOTE Circuit breakers are not suitable.

- d) protected against the effects of fire;
- e) of sufficient capacity to ensure conformity to **5.3.3**;
- f) operated automatically on demand;
- g) continuously rated;
- h) constructed from corrosion-resistant material; and
- i) located such that it is unlikely to be affected by flooding.

To ensure ease of maintenance, stop valves should be installed immediately upstream and downstream of the pump (see Annex A).

The electrical supply to the pumps should be installed so as to minimize the risk of electrical supply failure by having a separately fused connection taken after the meter and from the supply side of the consumer unit (see BS 7671), using approved fire-resistant cabling (see BS 7671).

Where there are two or more pumps, they should be fused so that the failure of one pump does not cause the failure of the other pump(s).

5.12.2 Combined sprinkler and domestic supply pump

NOTE In many situations, a combined sprinkler and cold water pump is more robust than a dedicated sprinkler pump, as the pump is in constant use and therefore a fault becomes apparent and can be fixed extremely quickly.

When a pump is to supply both the sprinkler system and the domestic supply, the pump should be in accordance with **5.12.1**.

5.12.3 Dedicated sprinkler pump

Where a dedicated pump is used, in addition to **5.12.1**, it should be:

- a) designed to include an automatic test cycle where the pump is activated at least monthly;
- b) operated automatically on demand but requiring manual shut down; and

- c) operated by either of two approved pressure-sensing devices with the circuitry for the pressure-sensing devices monitored.

A fault alarm should be raised if the electrical power or the automatic test cycle fails.

5.12.4 Enhanced water supply

For all category 4 systems (and category 2 or 3 systems, where additional resilience is sought) an enhanced water supply should be used which provides additional reliability. An enhanced water supply should conform to the requirements for water supplies (see **5.11**) and pumps (see **5.12**) and have the following additional requirements.

The enhanced water supply should have two or more half capacity tanks feeding two or more pumps, and configured so each pump can draw water from each tank and arranged so that any one pump or each tank can be isolated for maintenance.

NOTE 1 This could be a combined split tank.

Where more than one dedicated sprinkler pump is used to provide an enhanced water supply, the pumps should be configured to work independently of each other.

The electrical supply should be provided with a back-up power supply and automatic changeover functionality, such as:

- a) an emergency generator;
- b) uninterrupted power supplies; and
- c) two separate supplies.

NOTE 2 See BS 9991:2015, Clause 15 for further information.

NOTE 3 Power supplies are to be sized to accommodate simultaneous starting of all pumps.

5.13 Pipes and fittings

All pipes and fittings should be supplied, stored, handled, used and installed in accordance with the relevant British Standard, or other nationally recognized standard, appropriate for the particular material being used.

Copper tube conforming to BS EN 1057:2006+A1, R250 should be used above ground. Copper tube conforming to BS EN 1057:2006+A1, used in underground locations, should be R220 (annealed), thick walled, factory plastic coated tube. In this case, fittings should be manipulative Type B. Brass fittings in underground locations should be immune to de-zincification.

Capillary fittings should be joined by soldering or brazing with alloys with a melting point of not less than 230 °C, in accordance with BS EN ISO 9453. Above ground, threaded steel pipes and fittings should be in accordance with BS EN 10255 and BS EN 10266-1. Other metallic or non-metallic pipes, flexible connections, fittings and jointing systems should be approved for use in sprinkler systems and be installed in accordance with the manufacturer's instructions.

Plastics and other pipes and fittings should be approved for use in fire protection systems and should be installed in accordance with the supplier's instructions and be in accordance with either BRE publication LPS 1260, FM class 1637 or UL 2443.

Plastic pipe should be used only in wet pipe systems, and should be behind a fire-resisting barrier if it could be affected by a fire, e.g. if the pipework runs through an area without the protection of a suppression system.

NOTE Particular attention is drawn to the installation and usage guides associated with sprinkler pipework and fitting systems. Some piping system types have requirements and limitations that are critical to their performance.

5.14 Flexible sprinkler connection

NOTE A flexible sprinkler connection can be used between the distribution pipe and the sprinkler head.

Flexible sprinkler connections should:

- a) be in accordance with either BRE publication LPS 1261, FM class 1637 or UL 2443;

- b) be designed and manufactured for use in a fire sprinkler system and installed to the manufacturer's instructions;
- c) only connect a single sprinkler to the distribution pipe;
- d) be coupled to the distribution pipe with a minimum of 25mm DN fitting;
- e) have a minimum internal diameter of not less than 20 mm;
- f) not exceed 1.22 m in length;
- g) Ensure the number of bends and the radius are in accordance with the manufacturer's instructions;
- h) only use brackets which have been supplied and approved by the flexible sprinkler, connection manufacturer;
- i) replace flexible sprinkler connections which are damaged or kinked; and
- j) Ensure that the hydraulic calculation takes in to account the equivalent length of the flexible sprinkler connection, which is to be supplied by the manufacturer.

5.15 Valves

All valves should be supplied, stored, handled, used and installed in accordance with the relevant British Standard, or other nationally recognized standard.

The-sprinkler system should include (see Annex A):

- a) a suitable backflow prevention device (see **5.11.5**);

NOTE 1 See Annex A, Figure A1 – reverse items 3 and 4.

NOTE 2 Mains water supply is normally classified as class 2 and a flat face spring loaded single check valve is considered to be appropriate. With the addition of antifreeze a RPZ type device is now considered to be appropriate.

- b) a monitored lockable full bore stop valve. The valve should be locked in the open position to prevent accidental or deliberate interruption of the water supply to the sprinkler system;
- c) where appropriate, a priority demand valve;
- d) an alarm test valve;
- e) a full bore drain valve facility fitted at the lowest point of the sprinkler pipework to allow the complete draining of the sprinkler system;
- f) a test valve facility fitted downstream of the flow switch to allow testing of the switch, suitably sized to check the appropriate minimum system flow rate;

NOTE 3 The drain and test valves can be combined if suitably located to serve both functions.

- g) an installation pressure gauge conforming to BS EN 837-1 (with the facility to be removed and replaced without system draining), minimum nominal diameter 50 mm, class 1.6; and

NOTE 4 For example, a no loss or check valve device. An inline isolation valve is not acceptable.

- h) measures to prevent tampering with components of a sprinkler system that would isolate the water supply from the rest of the sprinkler system.

Except for category 1 systems, all valves which control the flow of water to the system should be electrically monitored for the open position.

Stop valves should not be installed downstream of the control valve or pump set except for zone control valves which should be monitored for the open position.

5.16 Pressure reducing valves

Pressure reducing valves should only be used where they serve both the sprinkler and domestic demands.

Pressure reducing valves should not be used unless necessary.

The pressure reducing valve should be in accordance with BS EN 1567 and be capable of delivering the maximum anticipated flow and pressure downstream of the valve.

Immediately downstream of each pressure reducing valve there should be a pressure gauge and a test valve (lockable ball valve) which is sufficient in size to take the maximum anticipated flow for use in commissioning and maintenance of the valve.

NOTE This is part of the valve set assembly.

Pressure reducing valves should be accessible for maintenance and securely located so that they cannot be tampered with.

A data label (see Annex F for an example) should at the valve set immediately downstream of to the pressure reducing valve.

The flow of water discharged at the test valve at commissioning and each maintenance interval should be taken into account.

5.17 Frost protection

COMMENTARY ON 5.17

Freezing can lead to burst pipes, inhibiting the movement of water through the sprinkler system and preventing discharge from the sprinklers.

Normal methods of protection against freezing include:

- a) *installing pipework within the heated envelope of the dwelling; and*
- b) *the use of lagging and trace heating.*

Unlike water in domestic water systems, water in sprinkler systems is not replenished by warmer water in normal circumstances. Therefore the water in a sprinkler system continues to lose heat until it reaches ambient air temperature and can easily freeze, despite being lagged. Exposed pipework, unless adequately protected, can also be affected by wind-chill leading to the freezing of the contents, even when ambient temperatures are above 0 °C.

Any water-filled pipework, pump(s) or container(s) used in the sprinkler system, which might be subjected to temperatures below 4 °C, should be protected against freezing.

5.18 Sprinkler system fire alarm functionality

COMMENTARY ON 5.18

Whilst in some domestic and residential buildings the actuation of the fire detection and alarm system triggers immediate and total evacuation of the premises, other residential buildings are designed so that the initial alarm is sounded only in the dwelling where the fire starts, as only this dwelling needs to evacuate immediately. The sprinkler fire alarm may or may not be integrated with the fire detection and alarm system for building. It is important that the configuration of the sprinkler fire alarm is matched to the building's fire evacuation strategy and any fire detection and alarm provision in the building.

If a building or dwelling has automatic fire detection and alarm provision that provides adequate fire alarm and warning arrangements to initiate evacuation, additional sprinkler fire alarms to initiate evacuation might be unnecessary.

In some cases there can be benefits for reducing property damage, especially in unoccupied areas, if an external sprinkler fire alarm is installed in a prominent location where people can be alerted to a sprinkler actuation.

Because sprinklers have a high level of reliability in fire situations, coupled with very few unwanted actuations, the sprinkler fire alarm needs to be treated as a confirmed fire signal.

Owing to the burden caused by false alarms, many fire and rescue services have introduced measures to reduce attendance to alarms generated by automatic fire alarm systems. Therefore to ensure an emergency response to a sprinkler fire alarm, consideration needs to be given to clearly distinguishing a sprinkler-initiated fire alarm from a signal generated by automatic fire detection. Early consultation with the local fire and rescue service can assist in developing an appropriate solution.

5.18.1 All buildings

All systems should have at least one sprinkler alarm initiating device. Devices to detect the operation of sprinkler systems should be either water flow detectors conforming to BS EN 12259-5 which detect the flow of a single sprinkler operation at the anticipated lowest flow rate or a pressure switch suitable for the intended use. The devices should be installed in accordance with the manufacturer's instructions.

If a pressure switches is used to actuate the sprinkler alarm, it should only be used on the alarm line of a wet alarm valve in accordance with BS EN 12259-2.

The sprinkler system alarm functionality should be integrated into the protected premises in a way which is compatible with the fire strategy for the protected premises (see 4.2.2 on fire strategy).

In all cases, the sprinkler fire alarm initiating device should generate a sprinkler fire alarm signal that initiates the appropriate emergency procedures.

The sprinkler system fire alarm functionality should be integrated into the protected premises.

NOTE 1 Examples of ways to integrate the sprinkler system fire alarm functionality include:

- a) *actuate a local fire alarm only; or*
- b) *actuate the fire alarm for the whole or part of the protected premises; or*
- c) *transmit a sprinkler system fire alarm to a permanently attended off-site alarm receiving centre, with suitable response procedures in place; or*
- d) *other solutions that may be necessitated by the fire strategy.*

Where the protected premises is to be fitted with automatic fire detection and alarm systems, they should be in accordance with BS 5839 and be to at least the minimum grade and category recommended in BS 5839. The sprinkler fire alarm initiating device(s) may be interfaced with these systems, however any such interface should be in accordance with BS 5839-1 or BS 5839-6, as appropriate.

NOTE 2 BS 5839-1:2013, Table A.1 and BS 5839-6:2013, Table 1 provide guidance on the category of system for the relevant property types.

When sprinkler fire alarm initiating devices are interfaced with automatic fire detection and alarm systems, actuation of the sprinkler fire alarm should be clearly distinguishable on any fire alarm control and indicating equipment.

5.18.2 Additional recommendations for multi-storey blocks of flats

NOTE See commentary on 5.18.

A sprinkler flow switch should be provided for every dwelling to signal the actuation of the sprinkler system within the dwelling. Alternatively, sprinkler flow switches may be configured to serve a sprinkler alarm zone, rather than each individual dwelling, provided the following recommendations are met:

- a) the sprinkler alarm zone should cover no more than a single floor; and
- b) sprinkler flow switches should be connected to suitable control and indicating equipment so that a signal is sent to management and any emergency action plan initiated.

In multi-staircase buildings, the control equipment should clearly indicate the floor level and appropriate staircase (where staircases serve different zones).

5.18.3 Electrically operated alarm devices

All electrically operated alarm devices should be capable of carrying out their function in the event of a complete failure of the mains electrical power supply.

6 Installation, commissioning and documentation

6.1 Installation

6.1.1 General

Sprinkler systems should be installed by a competent person and in accordance with the designer's specification.

6.1.2 Pipework

6.1.2.1 General

All pipework should be stored, handled and installed in accordance with the manufacturer's instructions.

Where appropriate, sprinkler system pipework should be installed in accordance with BS EN 805, BS EN 806 and BS 8558.

NOTE See also the WRAS Water Regulations guide [12].

6.1.2.2 Pipework support

Pipework supports should:

- a) be fixed directly to the structural elements or primary supports of the building;
- b) not be used to support any other services;
- c) be able to resist high temperatures without loss of strength;
- d) prevent the pipe from being dislodged;
- e) be secured in accordance with the manufacturer's instructions;
- f) not be glued, welded or soldered to the pipe or fittings;
- g) where necessary, be suitably lined to prevent corrosion and abrasion;
- h) be fitted as close as practically possible to the sprinkler heads in order to ensure that no movement occurs which would recoil heads into the ceiling or loft voids;
- i) be no closer than 0.15 m to an upright sprinkler; and
- j) have a maximum pipework support spacing in accordance with the manufacturer's installation instructions. Where no instructions are available, the maximum spacing should be in accordance with Annex D.

6.1.2.3 Pipework through construction elements

Structural timbers should not be notched or bored in such a way that the integrity of the structure is compromised.

Pipework passing through fire resisting elements of a structure should be adequately fire stopped.

6.1.3 Sprinkler heads

Sprinkler heads should be stored, handled and installed in accordance with the manufacturer's instructions.

Particular care should be taken so that:

- a) vent holes are not obstructed, e.g. through the use of insulation, concreting or boxing in;
- b) the sprinkler heads are not damaged in any way prior to fitting; especially the glass bulb or fusible link and the deflector; and
- c) the sprinklers are installed using the appropriate wrench supplied by the sprinkler manufacturer.

Protective covers should be left in place until the installation has been completed and the system is about to be commissioned (see **6.2**).

6.2 Commissioning

6.2.1 General

In addition to a full visual inspection, the tests in **6.2.2**, **6.2.3** and **6.2.4** should be passed for the system to become operational.

6.2.2 Leakage test

The installation pipework should be pressurized to a minimum pressure of 15 bar, or to 1.5 times the maximum working pressure, whichever is the greater, for 1 h. If the sprinkler system fails to maintain pressure, the leak should be found and corrected and this test repeated.

NOTE 1 1 bar = 105 N/m² = 100 kPa.

Care should be taken not to subject any system components to pressure higher than those recommended by the manufacturer.

NOTE 2 It is essential that any alarm receiving centre to which alarm signals are relayed is notified before, and immediately after completion of, any tests that could result in an alarm signal.

NOTE 3 Extensions and/or alterations should be tested in accordance with this subclause. Existing parts of the systems, including connections to the new system, should be tested at the pressure they were originally commissioned.

6.2.3 Hydraulic test

The sprinkler system should be tested to check that at least the design flow rate can be achieved at the design pressure when measured at the combined drain and alarm test valve. If this flow rate at the required pressure cannot be achieved, the system should not be approved for use until the system has been corrected and the test has been passed.

NOTE An example of a suitable test is given in Annex E.

If pressure reducing valves are installed (see **5.16**), a dynamic pressure and flow test should be carried out at each pressure reducing valve so that, as a minimum, the design flow rate can be achieved.

6.2.4 Alarm test

The alarm device should be tested by opening the alarm test valve to ensure a flow of water and checking that the alarm operates as designed (see **5.15**). Where the alarm is configured for remote monitoring, the signal to the monitoring station should be checked.

6.2.5 Compliance certificate

On satisfactory completion of the commissioning tests, a compliance certificate should be issued by the competent person in accordance with **6.3.3a**), which attests that the sprinkler system has been designed, installed and commissioned in accordance with this British Standard (see Note).

NOTE The design element of the certificate may be provided by another party.

Any variations from this British Standard should be agreed with the AHJ and be clearly stated on the compliance certificate.

6.3 Documentation

6.3.1 Presentation

For new and extended systems, all drawings and documents should bear, as a minimum, details of the system which include:

- a) the address and location of the premises or, in the case of transportable homes, the chassis or reference number;
- b) the name, address and contact details of the competent person;
- c) the name and address of the designer if different to the competent person; and
- d) the date of installation.

6.3.2 Log book

A log book (see **7.3**) should be provided to the occupier, and owner if appropriate, for each system containing all of the documentation listed in **6.3.3**.

6.3.3 Documents

The following information should be provided and be contained in the log book (see **6.3.2**):

- a) a statement of compliance with this British Standard in the form of a signed compliance certificate (see **6.2.5**)²⁾, together with any variations agreed with the AHJ and justification for the variation;
- b) category of system and number of design sprinklers;
- c) a general description of the system and a layout drawing of the premises, which should include as-fitted details, showing the extent of the installation, together with a set of the hydraulic calculations, including the system pressure and flow requirements;
- d) results of the commissioning tests;
- e) a list of components used, identifying the supplier's name and parts reference number;
- f) details of the authorities consulted and any response to consultation;
- g) details of the water supplies which, if a town main, should include pressure and flow rate data at a specified location for the commissioned installation, with the time and date of the test;
- h) a routine inspection and maintenance programme for the system;
- i) instructions on the actions to be taken in respect of operation of the system, faults, etc.;
- j) a 24 h emergency contact which can be used to obtain assistance; and
- k) essential information for the user, e.g. "do not paint, cover or in any way impede the operation of a sprinkler head", "no modification should be made to any sprinkler equipment except in accordance with BS 9251:2020".

6.4 Block plan

For all systems other than category 1, a laminated block plan of the premises should be provided by the installer with the following information.

- a) the location of the main shut off valve(s);
- b) tank volume and infill arrangements;
- c) fire service connection, where applicable;
- d) the area controlled by each control or zone valve;
- e) the location of corresponding control or zone valve(s); and
- f) location of pumps, tanks, alarm controls and electrical supply.

The block plan should be readily available to the fire service in an emergency.

The fire service might need information on how the system is designed to operate and the location of important controls in the case of an emergency; the block plan should provide this information and be easily located, a suitable location could be the fireman document box.

6.5 System data label

A label or notice should be attached or fixed adjacent to or on the sprinkler riser next to the main sprinkler stop valve as a permanent record of a system's design data.

NOTE 1 An example is given in Annex F.

NOTE 2 This is not the same as the compliance certificate (see 6.2.5).

6.6 Location plate

For all systems other than category 1, a location plate of weather-resistant material and lettering should be fixed on the outside of the external wall as close as practical to the entrance nearest the system valve set(s), an example is given in Figure 2.

²⁾ Such a certificate represents an installer's declaration of conformity, i.e. a claim by or on behalf of the installer that the system meets the recommendations of this British Standard. The accuracy of the claim is solely the claimant's responsibility. Such a declaration is not to be confused with third-party certification of conformity.

A sign should be fitted as close as possible to the main and any subsidiary stop valves. Where the stop valve is enclosed in a room with a door, the sign should be fixed on the outside of the door.

NOTE An example is given in Figure 2.

Figure 4 – Example of a location plate

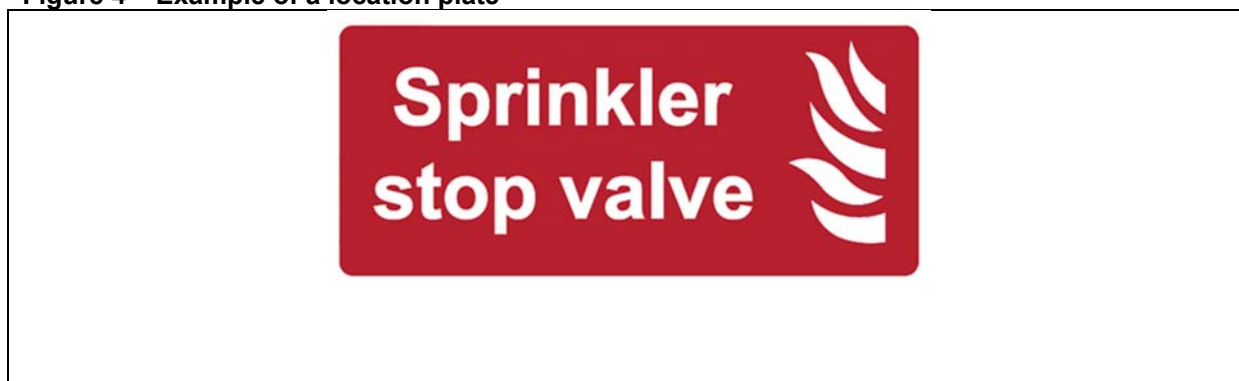
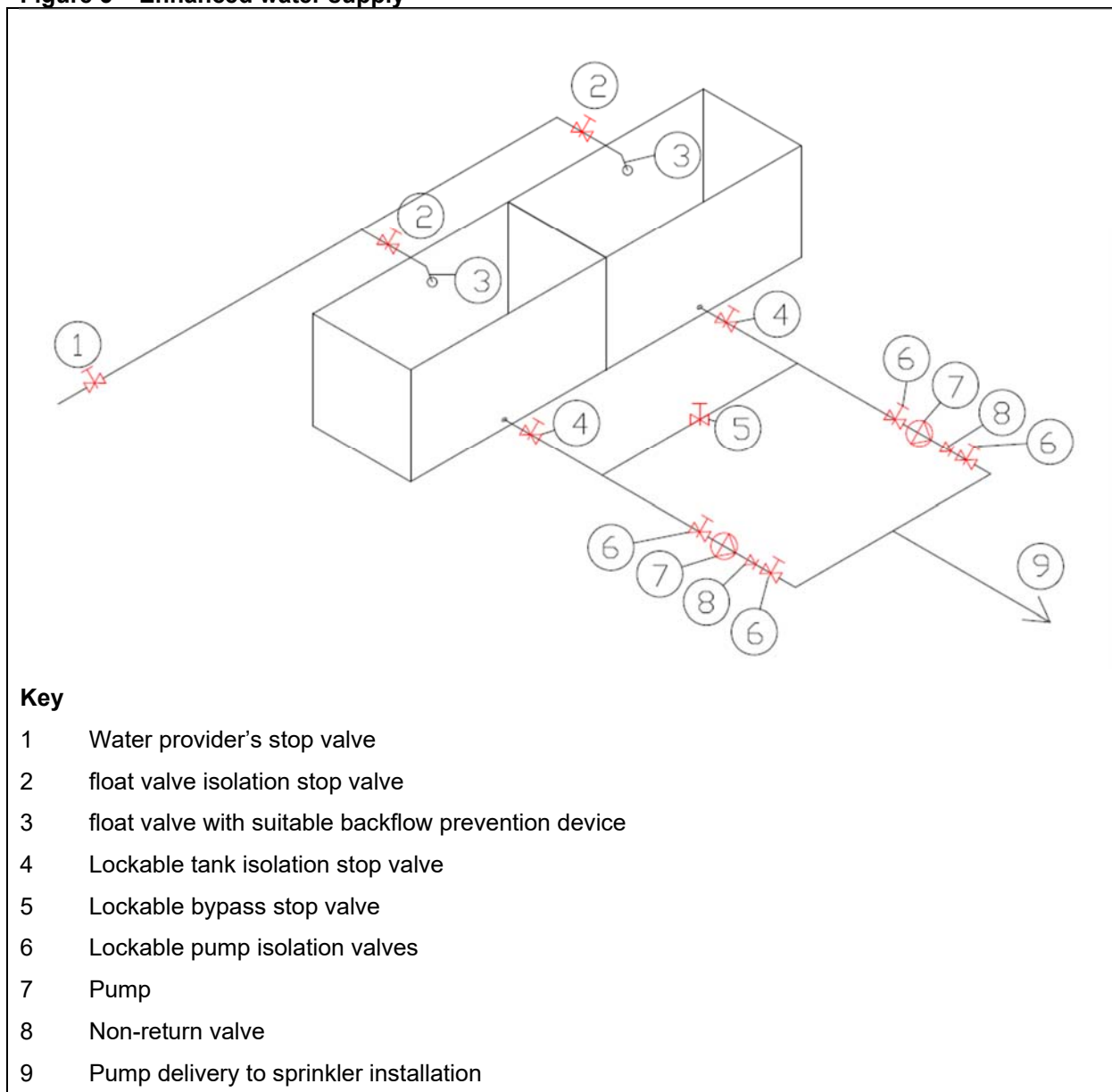

Figure 5 – Enhanced water supply



7 Maintenance

7.1 Inspecting and testing routines

7.1.1 General

The sprinkler system should be inspected and tested by a competent person in accordance with **6.2.1**, **6.2.3** and **6.2.4**.

The person carrying out the inspection should complete and sign the log book as recommended in **7.3**.

7.1.2 Yearly routine

At intervals not exceeding 12 months:

- a) the system should be visually inspected for leaks. If a leak is suspected the system should be inspected, tested and/or repaired, as necessary;
- b) the system should be inspected to determine whether any or all modifications have been carried out in accordance with this British Standard;

- c) where there has been a material alteration to the building, an increase in fire loading or a change to include vulnerable occupants, an assessment should be made as to whether the category of system is still appropriate (see 4.3);
- d) the sprinklers and any cover plates should be inspected to determine whether they have been tampered with or whether their heat sensing capacity or spray pattern has been impeded;
- e) valves should be exercised to ensure free movement and returned to their operational position, any locking mechanism should be checked and reinstated. Where monitoring is fitted, the correct function of the monitoring signals should be verified;
- f) the test valve should be operated to determine whether the system's design flow rate and pressure, as hydraulically calculated, is achieved. If pressure reducing valves are installed, the test should be carried out at the test valve downstream of the pressure reducing valves (see Annex E, Figure E.1) in addition to testing the main water supply;

NOTE 1 An example of a suitable test is given in Annex E.

- g) alarms should be tested to determine whether they are functioning as designed;
- h) backflow prevention devices should be maintained in accordance with the manufacturer's recommendations;
- i) any remote monitoring arrangements should be tested to determine whether they are being transmitted and received correctly;

NOTE 2 It is essential that any alarm receiving centre to which alarm signals are relayed is notified before, and immediately after completion of, any tests that could result in an alarm signal.

- j) where heating is installed to prevent the system from freezing its operation should be checked, e.g. tank heater and/or trace heating on pipework;
- k) water storage tanks should be visually inspected for debris and defects, e.g. signs of damage or corrosion. The correct operation of any low-level alarm should be verified. All tanks should be internally inspected and if necessary drained and cleaned;
- l) the correct operation of any automatic infill device should be verified; and
- m) for reduced capacity tanks, the infill flow rate should be verified.

NOTE 3 Maintenance of the system might be a legal requirement in some circumstances. It might also be a requirement of the building fire strategy.

7.1.3 Long-term inspection and testing

After 25 years the sprinklers and pipework should be inspected and tested in accordance with Annex G.

7.2 Reinstatement of the system

Reinstatement of the system following maintenance or actuation should be undertaken by a competent person and the log book (see 7.3) should be annotated to indicate the reason for reinstatement and any actions taken.

7.3 Log book

The log book referred to in 6.3.2 should be completed giving details of:

- a) the date of inspection;
- b) details of all tests conducted and their results;
- c) confirmation or otherwise of the sprinkler system's operational status;
- d) confirmation or otherwise of the alarm system's operational status;
- e) the time, date and location of any actuation, and details of subsequent reinstatement of the system; and
- f) details of any recommendations or comments.

Any serious system faults should be relayed to the occupants or owners as soon as possible, and confirmed in writing within 24 h.

Annex A (normative)

Zones, alarms and monitoring

COMMENTARY ON Annex A

This annex specifies requirements, which are additional to those elsewhere in the standard. They should be complied with whenever monitoring is specified.

A.1 Zoned installations

When a system is to be divided into zones each zone should:

- a) cover no more than one floor; and
- b) have no more than 500 sprinklers. Is this to higher number?

Each zone should be independently controlled by a single zone stop valve, installed in a readily accessible position in or near the zone it controls. Each valve should be secured open and be labelled to identify the area of protection it controls. The zone stop valve should be provided with devices to monitor the status of the valve (i.e. either fully open or not fully open).

Immediately downstream of the zone stop valve a water flow alarm device, capable of detecting a flow equal to or greater than that from any single sprinkler, should be installed in order to forward an alarm signal.

Permanent test and drainage facilities should be provided immediately downstream of the water flow alarm switch on each zone. The test facility should simulate operation of any single sprinkler. Adequate provision should be made for the disposal of waste water.

A.2 Sprinkler system monitoring

The aim of monitoring sprinkler systems is the continuous supervision of the main functions of the system, i.e. those whose failure might impair the correct automatic operation of the system in case of fire, and the raising of a supervisory alarm to allow corrective measures to be taken.

All devices used for monitoring should have at least IP 54 protection as specified in BS EN 60529 and be connected to a common supervisory alarm device. All signalling and alarm cabling should be fully supervised and should be given in the event of short or open circuit.

A.3 Stop valves controlling water flow to sprinklers

For Type 2, 3 and 4 systems, the position of all normally open stop valves should be monitored which could prevent water flowing to the sprinklers, including control valve sets, zone valves and other critical stop valves which could impair the system. An indication should be given whenever the valve is not open.

A.4 Water levels

An indication of low water level should be given before a water storage level drops more than 10% below its nominal fill level for a full holding capacity tank.

Annex B (informative)
Elements of a typical residential sprinkler system

The main elements of a typical residential sprinkler system are shown in Figure B.1 for mains-fed systems and Figure B.2 for pump and tank systems.

Figure B.1 – Elements of a typical mains-fed sprinkler system

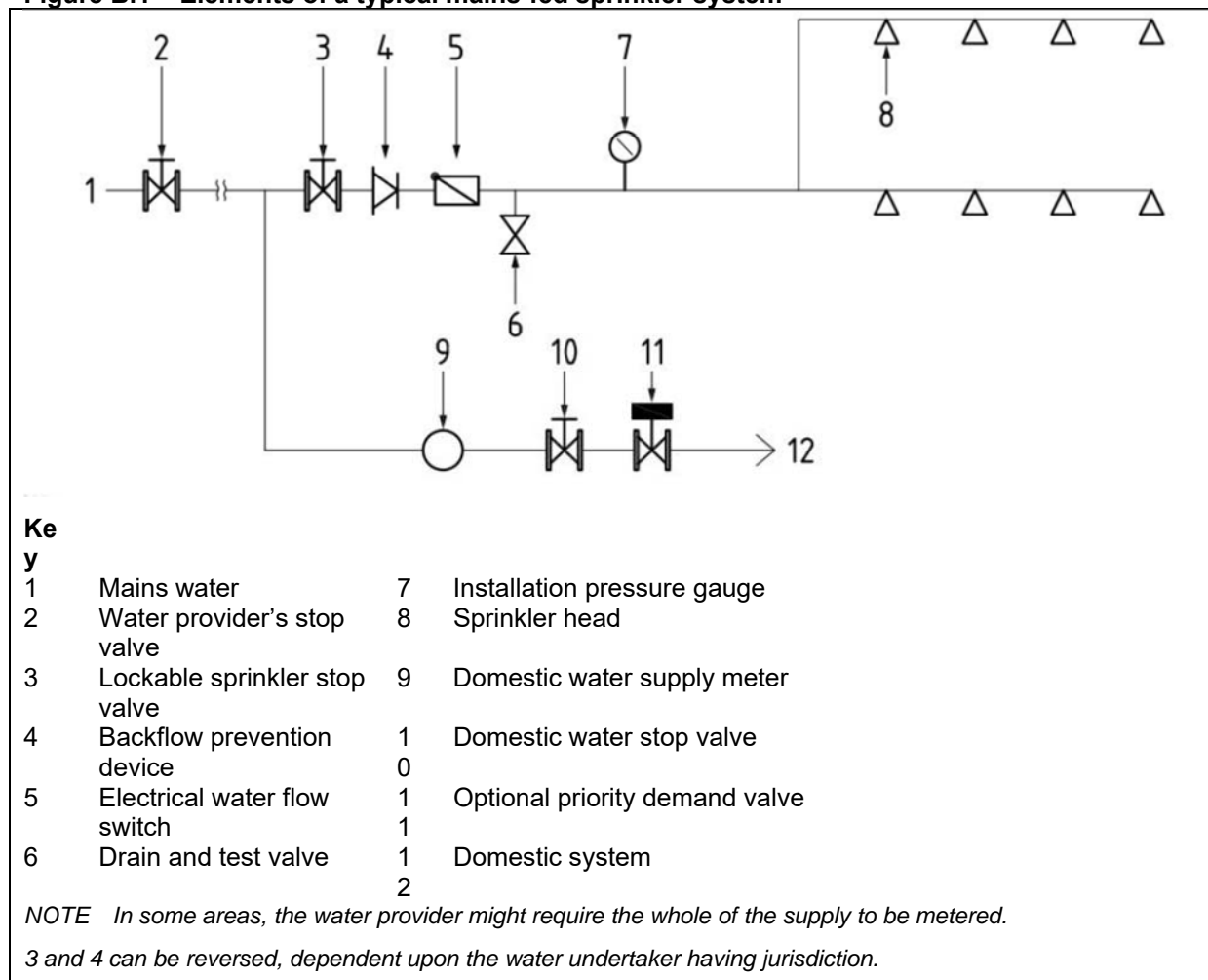
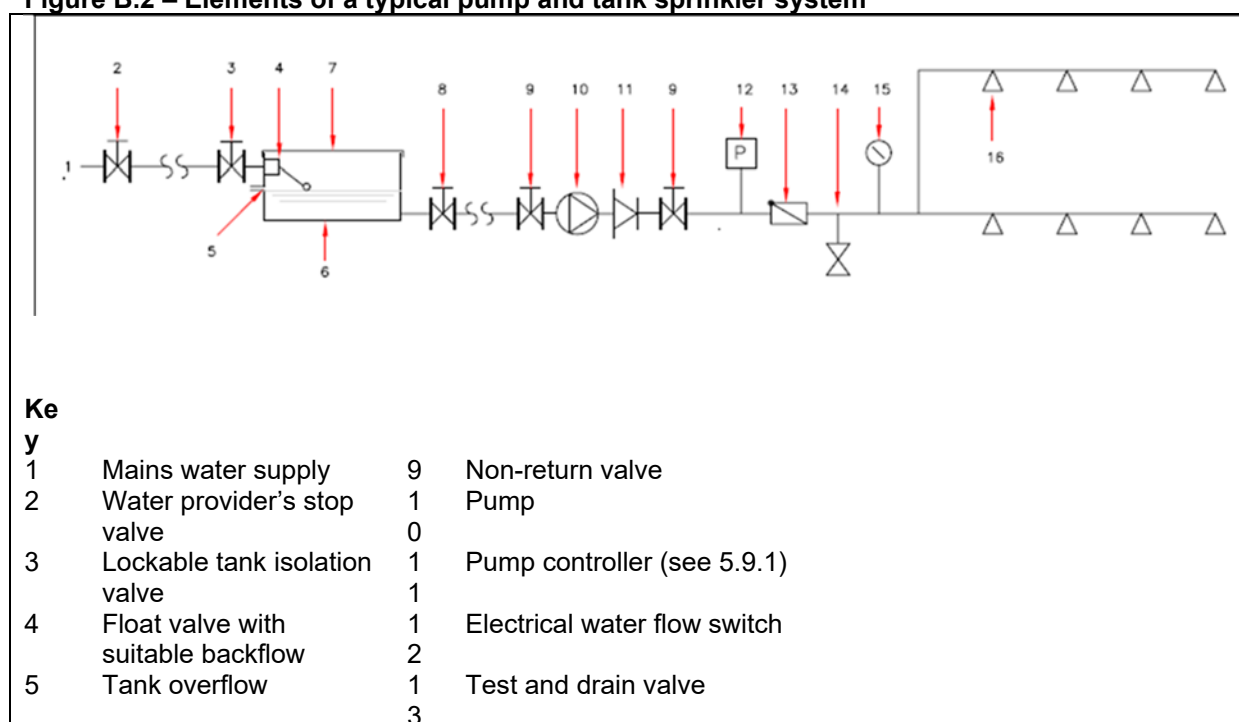

Figure B.2 – Elements of a typical pump and tank sprinkler system



6	Water storage tank	1	Installation pressure gauge
		4	
7	Tank lid	1	Sprinkler head
		5	
8	Lockable tank suction stop valve		

Annex C (normative) Hydraulic calculations

C.1 Static pressure

The static pressure difference between two inter-connecting vertical points in a system should be calculated from:

$$p = 0.098h$$

where:

- p is the pressure, in bar;
- h is the vertical distance between the two points, in metres (m).

NOTE If the calculations are undertaken by hand then the value of p may be rounded to 0.1.

C.2 Flow from a sprinkler head

The flow from a sprinkler head should be determined by the following formula:

$$Q = kp^{0.5}$$

where:

- Q is the flow, in litres per minute (L/min);
- k is the constant, sprinkler head nominal k -factor; p is the pressure, in bar.

C.3 Pipe friction loss

The pressure loss at a given flow through the pipework should be calculated using the Hazen–Williams formula:

$$p = \frac{6.05 \times 10^5}{C^{1.85} \times d^{4.87}} \times L \times Q^{1.85}$$

where:

- p is the pressure, in bar;
- C is a constant for the type and condition of the pipe (see Table D.1);
- d is the mean internal diameter of the pipe, in millimetres (mm);
- L is the equivalent length of pipe and fittings, in metres (m);
- Q is the flow, in litres per minute (L/min).

Table C.1 – C values for various type of pipes

Type of pipe	Value of C
Carbon steel	120
Copper	140
CPVC	150

NOTE This list is not exhaustive. Other values are given in BS EN 12845.

The pressure loss in the pipework for any given flow should be calculated using the appropriate K value from Table C.2a, Table C.2b or Table C.2c and by using the following formula:

$$p = K \times Q^{1.85} \times L$$

where:

- p is the pressure, in bar;

- K is a constant for the pipe type given in Table C.2a, Table C.2b and Table C.2c;
 Q is the flow, in litres per minute (L/min);
 L is the equivalent length of pipe and fittings, in metres (m);

Table C.2 – K values for carbon steel tube conforming to BS EN 10255, Medium series

Nominal diameter (mm)	Internal diameter (mm)	Value of K
20	21.70	2.67×10^{-5}
25	27.35	8.66×10^{-6}
32	36.05	2.25×10^{-6}
40	41.95	1.08×10^{-6}
50	53.05	3.44×10^{-7}
65	68.75	9.72×10^{-8}
80	80.75	4.44×10^{-8}

Table C.3 – K values for CPVC conforming to ASTM F442

Nominal diameter (mm)	Internal diameter (mm)	Value of K
20	22.20	1.58×10^{-5}
25	28.00	5.11×10^{-6}
32	35.40	1.63×10^{-6}
40	40.60	8.36×10^{-7}
50	50.90	2.78×10^{-7}
65	61.50	1.11×10^{-7}
80	75.00	4.21×10^{-8}

Table C.4 – K values for copper tube conforming to BS EN 1057:2006+A1, half-hard, R250 designation

Nominal diameter (mm)	Internal diameter (mm)	Value of K
22	20.2	2.85E-05
28	26.2	8.02E-06
35	32.6	2.77E-06
42	39.6	1.07E-06
54	51.6	2.96E-07

Table C.5 – Typical equivalent lengths for steel fittings and valves

Fittings and valves	Equivalent length in metres						
	20 mm ^{A)}	25 mm ^{A)}	32 mm ^{A)}	40 mm ^{A)}	50 mm ^{A)}	65 mm ^{A)}	80 mm ^{A)}
90° elbow	0.76	0.77	1.00	1.20	1.50	1.90	2.40
45° elbow	0.34	0.40	0.55	0.66	0.76	1.00	1.30
Tee or cross	1.30	1.50	2.10	2.40	2.90	3.80	4.80
Gate or full bore ball valve	0.20	0.30	0.30	0.30	0.38	0.51	0.63
Butterfly valve	1.00	1.10	1.50	1.80	2.20	2.90	3.60
Globe valve	7.30	8.80	11.30	12.80	16.00	21.00	26.00
Non-return valve (swing type)	2.70	3.40	4.00	4.60	5.80	6.70	3.90

Non-return valve (mushroom or spring assisted disc type)	4.30	5.60	6.00	7.90	12.00	19.00	19.70
Flow switch ^{B)}	1.60	2.05	2.65	3.11	4.04	5.30	6.70

NOTE The values given are based on a C-value of 120.

A) Nominal diameter.

B) Flow switch equivalent lengths have been derived on the basis of a maximum loss of 0.207 bar, at a flow rate equivalent to a velocity of 4.6 m/s.

C.4 Accuracy of calculations

The calculations should balance as follows:

- the algebraic sum of pressure loss in a loop should equal (0 ± 1) mbar;
- where water flows join at a junction, the calculation should balance to ± 1 mbar; and
- the algebraic sum of water flow at a junction should equal (0 ± 0.1) l/min.

C.5 Pressure loss through fittings and valves

The pressure loss due to friction in valves and fittings should be calculated using the Hazen-Williams formula in D.3 for the appropriate equivalent length.

The fitting or valve equivalent length should be taken from:

- the manufacturer's instructions, when available; or
- Table D.3, Table D.4 and Table D.5 for the appropriate material; and
- equivalent lengths of pipe for pulled bends in copper tube (in metres of pipe).

The frictional pressure loss in copper pipework bends where the direction of water flow is changed through 45° or more should be calculated using the formula:

$$L = 7.65 \times 10^{-3} Q^{0.15} d^{0.87}$$

where:

- L is the equivalent length, in metres (m);
- Q is the flow, in litres per minute (L/min);
- d is the mean internal diameter of the pipe, in millimetres (mm).

For any pipe fitting (bend, elbows, tee or cross) where there is a change in direction of flow and there is also a change in diameter at the same point, the equivalent pipe length and pressure loss should be determined by using the smaller diameter.

Table C.6 – Typical equivalent lengths for CPVC fittings and valves

Fittings and valves	Equivalent length in metres						
	20 mm ^{A)}	25 mm ^{A)}	32 mm ^{A)}	40 mm ^{A)}	50 mm ^{A)}	65 mm ^{A)}	80 mm ^{A)}
90° elbow	2.13	2.13	2.44	2.84	3.35	3.66	3.96
45° elbow	0.30	0.30	0.61	0.61	0.61	0.91	1.22
Tee branch	0.91	1.52	1.83	2.44	3.05	3.66	4.57
Tee run or coupling	0.30	0.30	0.30	0.30	0.30	0.61	0.61
Gate or full bore ball valve	0.30	0.45	0.45	0.45	0.57	0.77	0.94
Butterfly valve	1.51	1.66	2.26	2.72	3.32	4.38	5.36
Globe valve	7.30	10.00	13.00	16.00	22.00	24.10	38.74
Non-return valve (swing type)	4.23	5.13	6.04	6.95	8.76	10.12	12.00
Non-return valve (mushroom or spring assisted disc type)	6.49	8.46	9.06	11.93	18.12	28.69	38.74
Flow switch ^{B)}	2.42	3.10	4.00	4.70	6.10	8.00	10.00

NOTE The values given are based on a C-value of 150.

A) Nominal diameter.

B) Flow switch equivalent lengths have been derived on the basis of a maximum loss of 0.207 bar, at a flow rate equivalent to a velocity of 4.6 m/s.

Table C.7 – Typical equivalent lengths for copper fittings and valves

Fittings and valves	Equivalent length in metres					
	22 mm ^{A)}	28 mm ^{A)}	35 mm ^{A)}	42 mm ^{A)}	54 mm ^{A)}	67 mm ^{A)}
90° elbow	0.80	1.00	1.40	1.70	2.30	3.00
45° elbow	0.45	0.53	0.73	0.88	1.01	1.33
Tee	1.00	1.50	2.00	2.50	3.50	4.50
Gate or full bore ball valve	0.27	0.40	0.40	0.40	0.51	0.68
Butterfly valve	1.33	1.46	2.00	2.40	2.93	3.86
Globe valve	11.02	13.29	17.06	19.33	24.16	31.71
Non-return valve (swing type)	3.60	4.52	5.32	6.12	7.71	8.91
Non-return valve (mushroom or spring assisted disc type)	5.72	7.45	7.98	10.51	15.96	25.27
Flow switch ^{B)}	2.00	2.50	3.20	4.00	5.50	6.40

NOTE The values given are based on a C-value of 140.

A) Nominal diameter.

B) Flow switch equivalent lengths have been derived on the basis of a maximum loss of 0.207 bar, at a flow rate equivalent to a velocity of 4.6 m/s.

C.6 Maximum flow demand calculation

The maximum flow demand should be determined by either:

- full calculation, referencing the available water supply flow/pressure characteristics when applied to the calculated hydraulic demand point of the most favourable area; or
- determination of the intersect point of the available water supply flow/pressure characteristics with the calculated hydraulic demand point of the most favourable area, using a square law graduation graph referenced as an installer's pump test data sheet.

NOTE An example of using a square law graduation graph is shown in Figure D.1, and a blank template covering a range of appropriate flow rate and pressure requirements in Figure D.2. Figure D.1 indicates:

- the pump curve performance characteristics;
- the most unfavourable demand point at 98 L/min at 3.6 bar;
- the most favourable demand point at 98 L/min at 2.4 bar;
- the highest operating sprinkler located within the favourable area at 2.0 m high (equivalent to 0.196 bar);
- the maximum flow demand of 120 L/min.

Figure C.1 – Example of a square law graduation graph

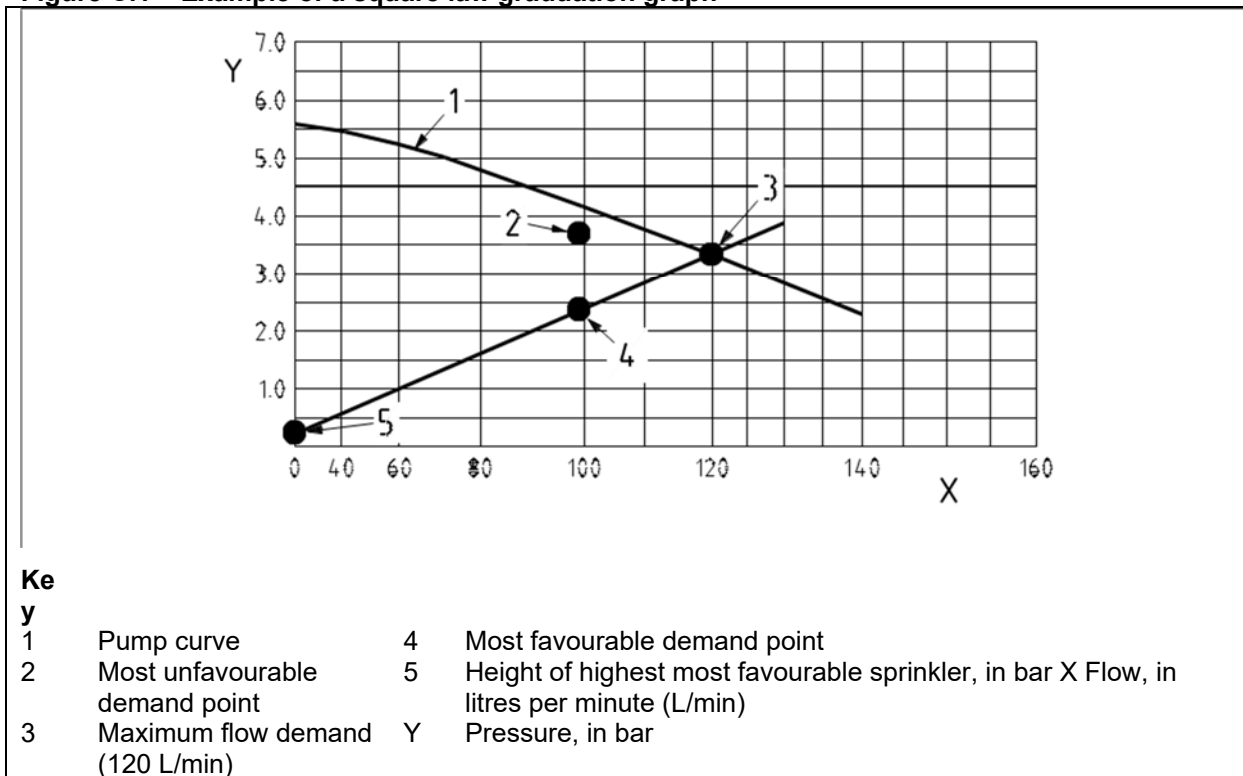
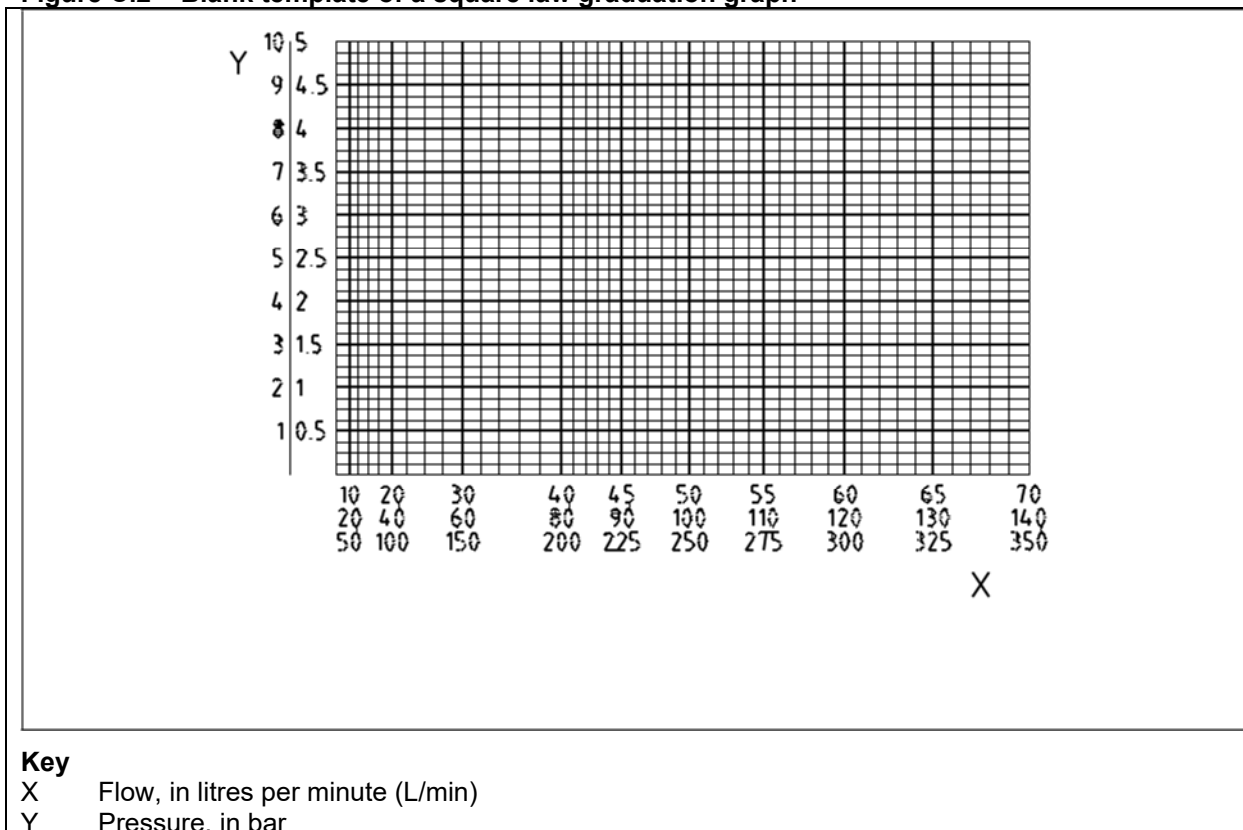

Figure C.2 – Blank template of a square law graduation graph



Annex D (normative)
Pipework support

In the absence of manufacturers' instructions, sprinkler system pipework should be supported at the intervals given in Table D.1, Table D.2 or Table D.3 as appropriate for the material being used.

Table D.1 – Maximum spacing of fixings for copper and stainless steel pipework

Nominal diameter mm	Horizontal run m	Vertical run m
22	1.8	2.4
28	1.8	2.4
35	2.4	3.0
42	2.4	3.0
54	2.7	3.6
67	3.0	3.6

Table D.2 – Maximum spacing of fixings for steel pipework

Nominal diameter mm	Horizontal run m	Vertical run m
15	1.8	2.4
20	2.4	3.0
25	2.4	3.0
32	2.7	3.0
40	3.0	3.6
50	3.0	3.6
80	3.6	4.5

Table D.3 – Maximum spacing of fixings for CPVC pipework

Nominal diameter mm	Horizontal run m	Vertical run m
20	1.7	3.0
25	1.8	3.0
32	2.0	3.0
40	2.1	3.0
50	2.4	3.0
65	2.7	3.0
80	3.0	3.0

Annex E (informative) Hydraulic test

COMMENTARY ON ANNEX E

Before testing begins, the as-fitted design pressure and the design flow for the system at the test point need to be ascertained.

This is the pressure requirement of the most remote sprinkler head(s), plus the pressure loss due to elevation and the intervening pipework. Both these pieces of information can be obtained from the system designer as part of the hydraulic calculations for the system.

The entire flow test assembly must have a working pressure at least equal to the system standing pressure being tested.

An example of a suitable test is as follows.

- a) Connect the flow test assembly to the sprinkler control Test and Drain valve (see Figure E.1).
- b) Connect a sufficient length of drain hose of at least equal internal bore to the end of the test rig, with the open end run to a suitable surface drain or receptacle. Ensure that the hose is as straight and level as practicably possible to minimise frictional losses. Do not submerge the open end of the drain pipe.
- c) Close the control valve (see Figure E.1) and slightly open the Test and Drain valve until pressure stabilises in the flow test assembly, then fully open the Test and Drain valve.
- d) Slowly open the Control Valve until the design requirement flow is registered on the Flow Meter **OR** design requirement pressure is registered on the Calibrated Pressure Gauge.
- e) Take readings from the Flow Meter and Calibrated Pressure Gauge and check that they both meet or exceed the design requirements of the system. If so then the water supply is deemed to be adequate.
- f) Test to be repeated for multiple design requirements.

Figure E.1 – Test rig for hydraulic test

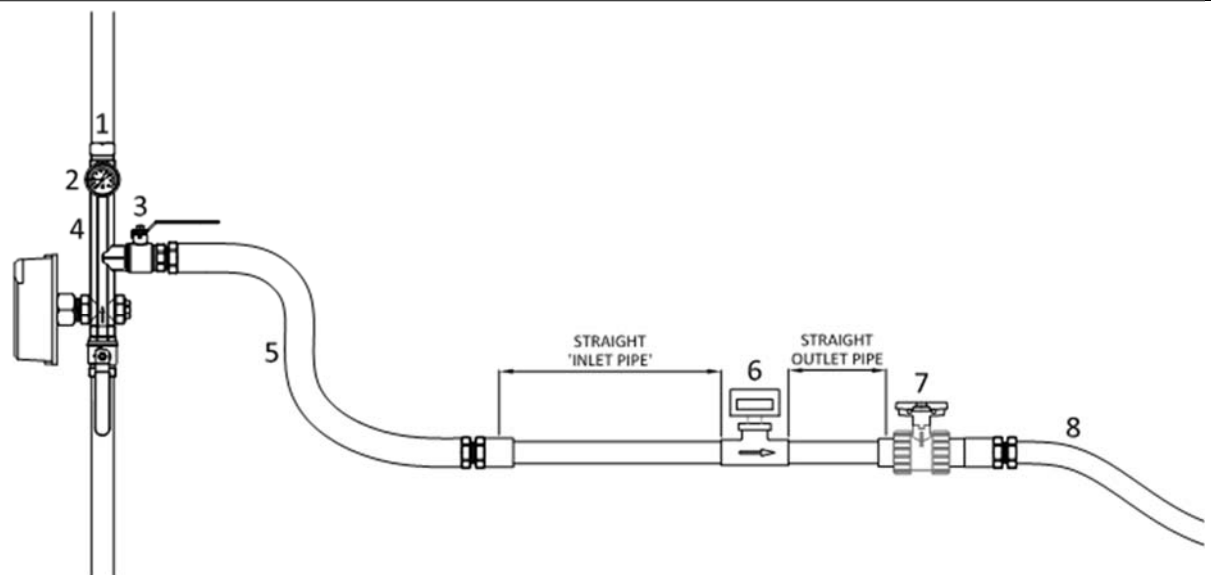

Key

- | | | | |
|---|---|---|-----------------------|
| 1 | Pipe to sprinkler protected area(s) | 6 | Calibrated flow meter |
| 2 | Calibrated pressure gauge ^{A), B)} | 7 | Control valve |
| 3 | Test and drain valve | 8 | Hose pipe to drain |
| 4 | Valve group or zone valve | | |
| 5 | Hose/pipe | | |

^{A)} Gauge position may be located on a branch (branch minimum 200 mm in length) between items 3 and 5, however the pressure reading is reduced due to frictional losses between item 4 and the gauge position.

^{B)} Glycerine filled valves are to be used for a more stable readout.

NOTE 1 Rigid, straight pipe sections are to be used before and after the flow meter to ensure laminar flow through the flow meter to obtain accurate results. The length of these pipes is to be as per the flow meter manufacturer's requirements.

NOTE 2 Hose/pipe sections must not have a smaller internal diameter than the nominal bore which the flow meter is designed for use with.

Annex F (informative)
Example of system data label

An example of a system data label is shown in Figure F.1.

Figure F.1 – Example of system data label

Sprinkler system data	
Installed at:	<i>123 Main Street, Town, County, Postcode</i>
Installation date	<i>month/year</i>
Design specification	
Code of practice	<i>BS 9251:2020</i>
Category of system	<i>Category 1</i>
Hydraulic data	
Sprinklers operating	<i>2 No.</i>
Flow/pressure demand	<i>100 L/min @ 2.5 bar</i>
Installing contractor	
<i>Name</i>	Contract Reference No.
<i>Address</i>	<i>AB1234</i>
<i>Logo</i>	
Third party certification body, if appropriate	<i>Name</i>
Certificate URN	<i>CD5678</i>

Annex G (normative)

Long term inspection and testing of pipework and sprinklers

After 25 years the pipework and the sprinklers should be inspected.

The pipework should be thoroughly flushed out and hydrostatically tested to a minimum pressure of 15 bar, or to 1.5 times the maximum working pressure, whichever is the greater, for 1 h. If the sprinkler system fails to maintain pressure, the leak should be found and corrected and this test repeated.

The pipe work should be internally and externally inspected. At least one metre length of range pipe should be inspected per 100 sprinklers. Two pipe sections of at least one metre length of each pipe diameter should be inspected.

All defects which might adversely affect the performance of the system should be eliminated.

A number of sprinklers should be removed and tested. Table E.1 specifies the scope of sampling as a function of the total number of sprinklers installed.

Table G.1 – Number of sprinklers to be removed and tested

Total number of sprinklers installed	Number of sprinklers to be tested
≤ 100	3
≤ 500	6

The sprinklers should be evaluated for the following:

- visual inspection of sprinkler and thermal element integrity;
- function; (in accordance with BS EN 12259-1:1999, **4.6**)
- operation temperature; (in accordance with BS EN 12259-1:1999, **4.6**)
- variation of K-factor; (in accordance with BS EN 12259-1:1999, annex C)
- thermal sensitivity: (in accordance with BS EN 12259-1:1999, **4.15**)

NOTE 1 Where failures of in-service sprinklers are noted in these tests, it might be necessary to conduct further investigation or replace all sprinklers representative of the batch tested.

NOTE 2 The selection and removal of sprinklers should be undertaken in accordance with the following recommendations.

- Sprinklers should be taken from a variety of locations that are representative of the range of environmental conditions that they have been subject to in service.*
- Removed sprinklers should be replaced with sprinklers appropriate to the system design.*
- Sprinklers should be removed using the manufacturer's recommended procedure and (if applicable) tools.*
- No attempt should be made to clean any part of the sprinkler*
- Sprinklers should be tagged with the following information:*
 - building address and use (e.g. dwelling, residential care etc);*
 - minimum system standby pressure;*
 - location within building (e.g. bedroom, kitchen, corridor).*

Bibliography

Standards publications

For dated references, only the edition cited applies. For undated references, the latest edition of the referenced document (including any amendments) applies.

BS 1710, *Specification for identification of pipelines and services*

BS 5306-0:2011, *Fire protection installations and equipment on premises – Part 0: Guide for selection of installed systems and other fire equipment*

BS 9991, *Fire safety in the design, management and use of residential buildings – Code of practice*

BS 9999, *Code of practice for fire safety in the design, management and use of building*

BS EN 1717:2000, *Protection against pollution of potable water in water installations and general requirements of devices to prevent pollution by backflow*

Other publications

- [1] DEPARTMENT FOR COMMUNITIES AND LOCAL GOVERNMENT. *The Building Regulations 2010 – Approved Document B (fire safety) volume 1: Dwellings, 2019 edition* for use in England. London: National Building Specification (NBS), 2019.
- [2] DEPARTMENT FOR COMMUNITIES AND LOCAL GOVERNMENT. *The Building Regulations 2010 – Approved Document B (fire safety) volume 2: Buildings other than dwellings, 2019 edition* for use in England. London: National Building Specification (NBS), 2019.
- [3] WELSH GOVERNMENT (DEPARTMENT FOR COMMUNITIES AND LOCAL GOVERNMENT publication). *The Building Regulations 2010 – Approved Document B: Fire safety – Volume 1: Dwellinghouses. 2006 edition incorporating 2010 and 2016 amendments* for use in Wales. Crown copyright, 2016.
- [4] WELSH GOVERNMENT. *The Building Regulations 2010 – Approved Document B: Fire safety – Volume 2: Buildings other than dwellinghouses. 2006 edition incorporating 2010, 2013 and 2016 amendments* for use in Wales. Crown copyright, 2016.
- [5] SCOTTISH BUILDING STANDARDS AGENCY. *The Scottish Building Standards Technical Handbook 2019: Domestic*. Edinburgh: Scottish Government, 2019
- [6] SCOTTISH BUILDING STANDARDS AGENCY. *The Scottish Building Standards Technical Handbook 2019: Non-domestic*. Edinburgh: Scottish Government, 2019
- [6] NORTHERN IRELAND DEPARTMENT OF FINANCE AND PERSONNEL. *The Building Regulations (NI) 2012 Technical Booklet E – Fire safety*. Belfast: The Stationery Office, 2012.
- [7] GREAT BRITAIN. *Water Supply (Water Fittings) Regulations 1999*. London: The Stationery Office.
- [8] SCOTTISH WATER. *Water Supply (Water Fittings) (Scotland) Byelaws 2014*. Edinburgh: Scottish Water.
- [9] GREAT BRITAIN. *Water Regulations (Northern Ireland) 2006*. London: The Stationery Office.
- [10] WATER UK. *Guidelines for the supply of water to automatic fire sprinkler systems*. Water UK, 2013
- [11] LOSS PREVENTION COUNCIL. *Legionella and fire-fighting systems – A technical briefing note*. Moreton in Marsh: Fire Protection Association, 1999.

[12] WATER REGULATIONS ADVISORY SCHEME. *Water Regulations guide*. Edition 2. Oakdale, Gwent: Water Regulations Advisory Scheme, 2001.